



## Dirt filters

### → FILTRY-P9 / 90 bar (1305 psig) (permanent use)

#### ■ Applications

- Permanent refrigerant filtering, regulation and expansion element protection in refrigerating and air conditioning installations.
- These filters are particularly suited for commercial refrigerating applications and installations with important liquid line lengths.

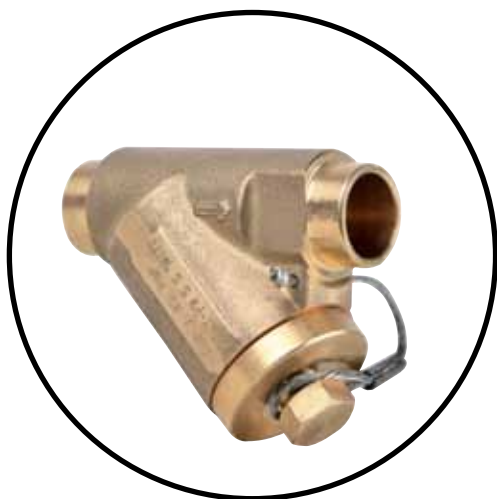

**90 bar**



**SUBCRITICAL AND TRANSCRITICAL**

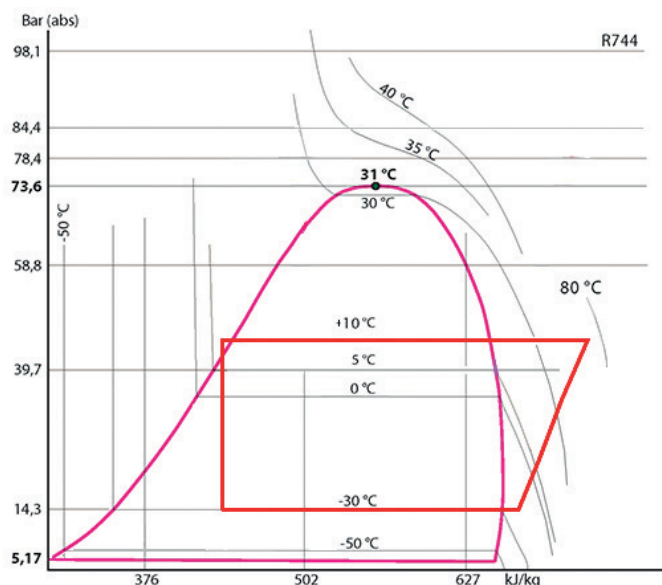

#### ■ Functional features

- Products are compatible with HFCs, CO<sub>2</sub>s, as well as with their associated oils and additives. Products are designed for use of non-hazardous refrigerants from group 2 of PED 97/23/EC.
- Product classification in CE categories is performed using the PED 97/23/EC table, corresponding to a nominal diameter-based selection.
- Product is ergonomic for quick maintenance interventions.
- Body made of die-cast brass with brazed connection.
- Filtration preventing propagation within the circuit of particles bigger than 50 microns with a filtration area of 16 cm<sup>2</sup>.

#### ■ CARLY advantages

- Maximal working pressure: up to 90 bar with CO<sub>2</sub> in subcritical and transcritical compression systems.
- The stainless steel filtrating sleeve can be removed for cleaning, without removing the filter case and without debrazing the connections, thus allowing important time savings during maintenance operations.
- Plug can be handled with a flat spanner and fitted with a safety metallic cable.
- Fastening plug in brass, can be handled with a spanner.
- Compact product for ease of assembly in reduced footprint.



CTCY-EN – 11.5-1 / 07-2015

# Dirt filters

## → FILTRY-P9 / 90 bar (1305 psig) *(permanent use)*

### ■ Warning

Before selecting or installing any component, please refer to the chapter 0 of CARLY technical catalogue - **WARNING**.

### ■ General assembly precautions

The installation of a component in a refrigeration system by a skilled professional, requires some precautions:

- Some are specific to each component, and in this case, they are specified in the **RECOMMENDATIONS SPECIFIC** part defined hereafter ;
- Other are general to all CARLY

components, they are presented in the chapter 115 of CARLY technical catalogue – **GENERAL ASSEMBLY PRECAUTIONS**.

### ■ Recommendations specific to dirt filters FILTRY-P9

- FILTRY-P9 dirt filters are to be mounted on the liquid line between the receiver and the expansion element.
- The refrigerant flow direction is indicated by an arrow on filter case. It must be complied with.
- The FILTRY-P9 dirt filters have to be mounted horizontally, the part with the strainer oriented downwards.
- It is mandatory to remove the filtrating sleeve and the O-ring before assembling filter by brazing.
- After brazing, when the base temperature is sufficiently low, put the O-ring back into its recess and screw back the plug complying with a six-side key with the recommended tightening torque of 15 N.m.
- After each removal of the plug, imperatively replace the PTFE O-ring; it is preferable to position, in a first step, the filtrating sleeve in the filter case and in a second step, to screw the plug.
- Be careful to properly select the solenoid valves located downstream of the filters; their oversizing could cause liquid hammer phenomena hindering the filters' proper mechanical behaviour; these liquid hammer phenomena can originate from other sources, in long-piping installations.
- Never install filters in an area of the circuit that can be isolated.
- Never trap refrigerant in its liquid state (between a check valve and a solenoid valve, for instance).
- It is mandatory to change or to clean the filtrating sleeves with a solvent when the pressure drop measured in the FILTRY-P9 filter is too important. CARLY recommends this operation at least once a year as prevention.



## Dirt filters

### → **FILTRY-P9 / 90 bar (1305 psig)** *(permanent use)*

#### ■ Special precautions for components used with CO<sub>2</sub> in sub. and transcritical systems

- The maximal working pressure and the power variations of the installation must be taken into account as of its design, in order to select all the components consequently.
- The pressure of the circuit during the stop phases must also be taken into account, because it can be very high, due to the pressure equalization according to the ambient temperature; several solutions exist to limit and control this pressure when the installation is stopped.
  - Design of the installation allowing to resist to this pressure.
  - Implementation of a « buffer » volume of storage or expansion (receiver).
  - Installation of a secondary circuit with valve or solenoid valve, allowing the fluid transfer to the coldest point, or the less high in pressure of the installation.
  - Implementation of a small separate refrigeration unit, to maintain the liquid temperature at a pressure lower than the maximal working pressure ; it is so far the most effective technical solution, but with a major drawback, which is the power failure (safety unit to be considered, or backup power supply).
- The hot gas defrost, frequently used with CO<sub>2</sub> for low temperatures applications, generates also high pressures (to take in consideration)
- The implementation on the liquid line of a filter drier **DCY-P14**, or a filter drier shell **BCY-P14** equipped with drying cores **CCY 48 HP** or **PLATINIUM 48**, is highly recommended. Serious problems can occur in the presence of moisture, such as expansion valve blocking and formation of dry ice and even carbonic acid. To avoid this, it is imperative to limit the circuit openings in order to avoid air introduction, causing the condensation in the pipes, and to proceed to a high evacuation of the installation, before any commissioning or restarting.
- For an operation with CO<sub>2</sub> at low temperature, provide thermal insulation on the components which can be covered by frost.
- There is no incompatibility between CO<sub>2</sub> and the main metallic materials commonly used in refrigeration systems (steel, copper, brass...)
- On the other hand, there is a real compatibility issue between CO<sub>2</sub> and polymers. For example, swelling phenomena and internal explosion of the seal are possible. Carly dirt filters FILTRY-P9 do not have polymer gaskets.



CTCY-EN – 11.5-1 / 07-2015

# Dirt filters

## → FILTRY-P9 / 90 bar (1305 psig) (permanent use)

### ■ Technical features

CARLY references	Connections to solder ODF inch	CARLY references	Connections to solder ODF mm	Filtering surface cm <sup>2</sup>	Filtering μm	Dimensions mm		
						L1	L2	L3
FILTRY-P9 2 S	1/4	FILTRY-P9 2 MMS	6	16	50	70	58	33
FILTRY-P9 3 S	3/8	FILTRY-P9 3 MMS	10	16	50	70	58	33
FILTRY-P9 4 S	1/2	FILTRY-P9 4 MMS	12	16	50	70	58	33
FILTRY-P9 5 S/MMS	5/8	FILTRY-P9 5 S/MMS	16	16	50	70	58	33

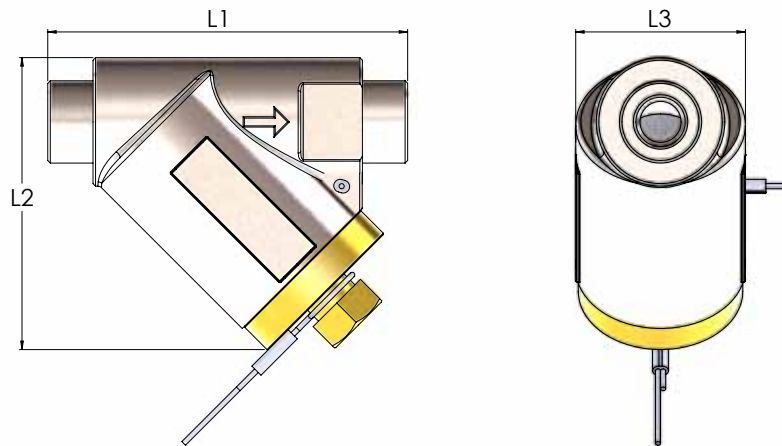

CARLY references	Nominal diameter	CARLY references	Nominal diameter	Maximal working pressure	Working pressure (1)	Maximal working temperature	Minimal working temperature	Working temperature (1)	CE Category (2)
	DN inch		DN mm						
FILTRY-P9 2 S	1/4	FILTRY-P9 2 MMS	6	90	15	100	-40	-30	Art 3§3
FILTRY-P9 3 S	3/8	FILTRY-P9 3 MMS	10	90	15	100	-40	-30	Art 3§3
FILTRY-P9 4 S	1/2	FILTRY-P9 4 MMS	12	90	15	100	-40	-30	Art 3§3
FILTRY-P9 5 S/MMS	5/8	FILTRY-P9 5 S/MMS	16	90	15	100	-40	-30	Art 3§3

(1) The working pressure is limited to the PS BT value when working temperature is lower than or equal to TS BT value.

(2) Classification by diameter, according to PED 97/23/EC (refer to chapter 0 to CARLY technical catalogue).



## Dirt filters

### → **FILTRY-P9 / 90 bar (1305 psig)** *(permanent use)*

#### ■ Spare parts

CARLY references	Part N°	Description	Quantity
CY 15552180	1	O-ring PTFE gasket	1
CY 11610050	2	50 microns filtrating sleeve	1

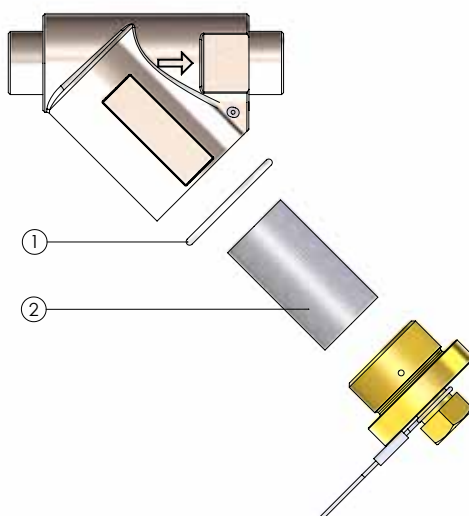

#### ■ Weights and packaging

CARLY references	Unit weight kg		Packaging number of pieces
	With packaging	Without packaging	
FILTRY-P9 2 S	0,31	0,30	1
FILTRY-P9 3 S	0,31	0,30	1
FILTRY-P9 4 S	0,31	0,30	1
FILTRY-P9 5 S/MMS	0,31	0,30	1