

# Commercial CO<sub>2</sub> Refrigeration Systems

## Guide for Subcritical and Transcritical CO<sub>2</sub> Applications



**EMERSON**<sup>™</sup>  
Climate Technologies



# Contents

<b>Chapter 1. Introduction</b>	<b>4</b>
<b>Chapter 2. CO<sub>2</sub> Basics and Considerations as a Refrigerant</b>	<b>5</b>
Section 1. Criteria for Refrigerant Selection.....	5
Section 2. Properties of R744.....	6
Section 3. An Introduction to Transcritical Operation.....	8
Section 4. Behaviour in the Reference Cycle.....	9
Section 5. R744 Hazards.....	10
Section 6. Comparison of R744 with other Refrigerants.....	12
Section 7. Advantages and Disadvantages of R744 as a Refrigerant.....	13
<b>Chapter 3. Introduction to R744 Systems</b>	<b>14</b>
Section 1. Introduction to Retail Transcritical Systems.....	14
Section 2. Introduction to Retail Cascade Systems.....	17
Section 3. Secondary Systems.....	18
Section 4. Selecting the Best System – Booster vs Cascade vs Secondary.....	19
<b>Chapter 4. R744 System Design</b>	<b>22</b>
Section 1. Transcritical Booster Systems.....	22
Section 2. Cascade Systems.....	24
Section 3. Secondary Systems.....	26
Section 4. Design for Pressure.....	27
Section 5. Design for Ease of Service.....	28
Section 6. Fixed Leak Detection.....	28
Section 7. Cooling Capacity.....	28
Section 8. Capacity Modulation.....	29
Section 9. Pipe Work and Jointing.....	29
Section 10. Lubricants and Oil Return.....	31
Section 11. Materials.....	31
Section 12. Potential for Heat Reclaim.....	31
<b>Chapter 5. R744 Systems - Installation, Commissioning and Service</b>	<b>32</b>
Section 1. Good Installation Practice.....	32
Section 2. Charging R744.....	34
Section 3. System Checks.....	35
Section 4. Service .....	35
Section 5. Putting the System Temporarily Out of Service.....	38
Section 6. Maintenance.....	38
Conclusion .....	39
<b>Glossary</b>	<b>40</b>
List of Figures .....	42
List of Tables .....	43
List of References .....	43

# 1 Introduction

Currently it is not an easy matter for decision makers in commercial refrigeration to make a definite choice of refrigerants and system type. For the last decade, many refrigerant options and system architectures have appeared both on paper and in practice. The sector has been in the environmental spotlight in recent years, especially as leakage studies have revealed the true effects of HFC emissions in centralised systems. Considerable reductions in emissions are certainly possible, but they do require changes.

Emerson Climate Technologies conducted a study on this topic, comparing various options. The conclusion was clear, there is no best option for key criteria, environment, cost and power consumption. A tool, Finding the Right Balance, is available on the Emerson website to enable customers to make tailored comparisons. Different options are likely to develop in the next decade depending on regional trends, legislation, genuine green initiatives and green image enhancement.

R744 (CO<sub>2</sub>) is a leading option for environmental reasons, and it can be a winner for power consumption as developments of component technology and application methods continue to reveal potential performance gains. Good experience has been gained with different system configurations over many years, particularly in central and northern Europe. The confidence resulting from this

experience ensures that CO<sub>2</sub> will be a long-term option in the foreseeable future.

CO<sub>2</sub> is termed a “Natural Refrigerant” because it exists in the natural environment. Release into the atmosphere from refrigeration systems has a negligible effect compared to other CO<sub>2</sub> sources that are driving the global warming debate. As a refrigerant, it is a manufactured product that conforms to strict purity specifications. Its physical properties require special handling. The system pressures are much higher than in conventional systems, and all the components are designed accordingly. Today there is no difficulty in sourcing all the necessary equipment. High investment costs were characteristic of early CO<sub>2</sub> projects, but these costs are now on a downward trend. The refrigerant itself is a fraction of the cost of some of the specialty HFCs.

This handbook reviews the main CO<sub>2</sub> properties, explores the advantages of CO<sub>2</sub> as a refrigerant, and provides an understanding of system types and their design. This is followed by a study of optimisation, operation and maintenance topics. This information will be useful to engineers responsible for designing and maintaining commercial refrigeration systems who are now encountering CO<sub>2</sub> systems, perhaps for the first time.



Figure 1. Copeland™ Stream compressor for R744



Figure 2. Copeland™ Scroll ZO compressor for R744

This chapter introduces carbon dioxide as a refrigerant, describes its properties and compares it to other refrigerants, both traditional and new. It outlines the hazards of CO<sub>2</sub> and explains why CO<sub>2</sub> refrigeration systems differ from conventional systems.

### Section 1. Criteria for Refrigerant Selection

Various criteria should be considered when selecting properties, safety, environmental impact, ease of use, and availability of components and expertise.

The following table lists the criteria that are important when selecting a refrigerant and shows how well R744 meets these criteria. More detail is provided later in this chapter.

R744 meets the demand for a natural refrigerant with a low global warming impact, but presents challenges in both its application and handling.

Table 1. How R744 meets different conditions and criteria

Criteria	How well does R744 meet the criteria?
Cooling capacity	Significantly higher volumetric capacity than conventional refrigerants
Efficiency	Efficiency depends on system type and ambient temperature
Operating conditions	Operating and standstill pressures significantly higher than for all other common retail refrigeration refrigerants
Environmental properties	Global Warming Potential (GWP) = 1, significantly lower than for commonly used HFCs
Availability of refrigerant	Varies globally but generally available
Availability of system components	Many components are different to those used on HFC retail systems, but these are now generally available
Availability of competent engineers and technicians	Varies globally but generally low; engineers must have a good understanding of basic refrigeration and good refrigeration practice and will require further training for R744
Cost	Refrigerant cost lower than for HFCs, but system costs are generally higher
Safety	Low toxicity and nonflammable: high-pressures and associated hazards present additional challenges
Ease of use	High-pressure and low critical point drive the need for more complex systems
Availability of appropriate standards	Safety Standards EN378 & ISO 5149 <sup>1</sup> include R744
Composition	Single molecule, no temperature glide in subcritical operations
Suitability as a retrofit refrigerant	Not suitable due to higher pressures

<sup>1</sup> EN378 Refrigerating systems and heat pumps – Safety and environmental requirements  
ISO 5149 mechanical refrigerating systems used for cooling and heating - Safety requirements.

## Section 2. Properties of R744

Carbon dioxide is a naturally occurring substance – the atmosphere is comprised of approximately 0.04% CO<sub>2</sub> (370 ppm). It is produced during respiration by most living organisms and is absorbed by plants. It is also produced during many industrial processes, in particular when fossil fuels such as coal, gas or oil are burned to generate power or drive vehicles.

The triple point of carbon dioxide is high and the critical point is low compared to other refrigerants. The chart in figure 3 shows the triple point and the critical point on a phase diagram.

The triple point occurs at 4.2 bar g and -57°C, below this point there is no liquid phase. At atmospheric pressure (0 bar g), solid R744 sublimes directly to a gas. Solid R744 will have a surface temperature of -78°C. If R744 is at a pressure higher than the triple point and it reduces to a pressure below the triple point (for example to atmospheric pressure), it will deposit directly to solid. This can occur when charging an evacuated refrigeration system with liquid R744 for example. Solid R744 is also known as dry ice.

The critical point occurs at 31°C, which is below typical system condensing temperatures for part or all of the year, depending on the climate. Above the critical point the refrigerant is a transcritical fluid. There is no phase

change when heat is removed from a transcritical fluid while it is above the critical pressure and temperature.

In a refrigeration system transcritical R744 will not condense until the pressure has dropped below the critical pressure. No other commonly used refrigerant has such a low critical temperature so they always condense as heat is removed on the high side of the system.

The **critical point** is the condition at which the liquid and gas densities are the same. Above this point distinct liquid and gas phases do not exist.

The **triple point** is the condition at which solid, liquid and gas co-exist. The glossary has a full explanation of the terms used in this section.

The boundaries of the transcritical fluid region are:

- The critical temperature (31°C) to the sub-cooled liquid region
- The critical pressure (72.8 bar g) to the superheated gas region

Table 2 on page 7 compares the basic properties of R744 with different refrigerants which are commonly used in the retail sector.

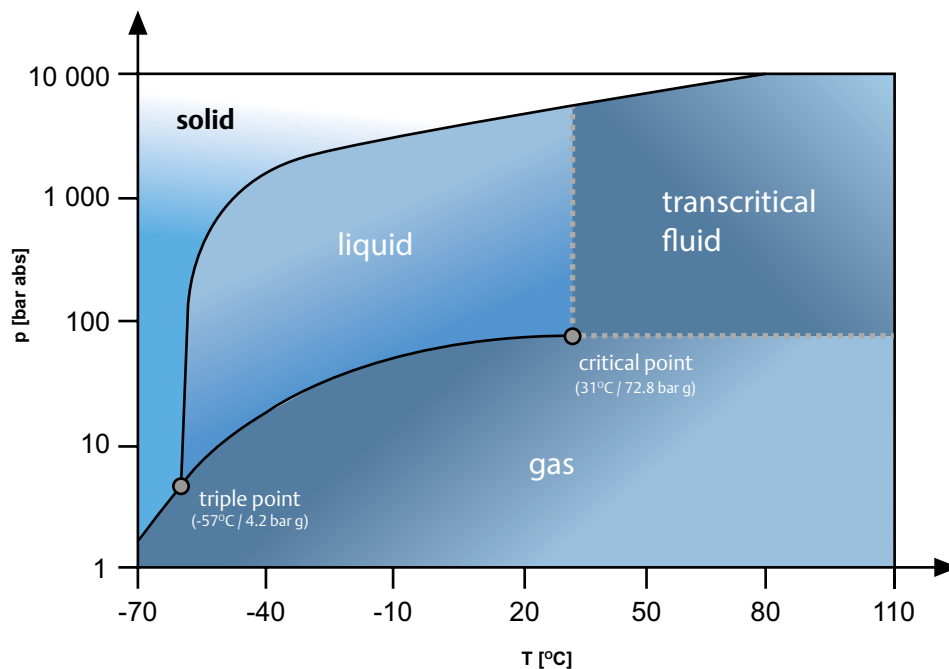

Figure 3. R744 / CO<sub>2</sub> phase diagram

The pressure enthalpy chart in figure 4 shows the critical point and the extent of the transcritical fluid region.

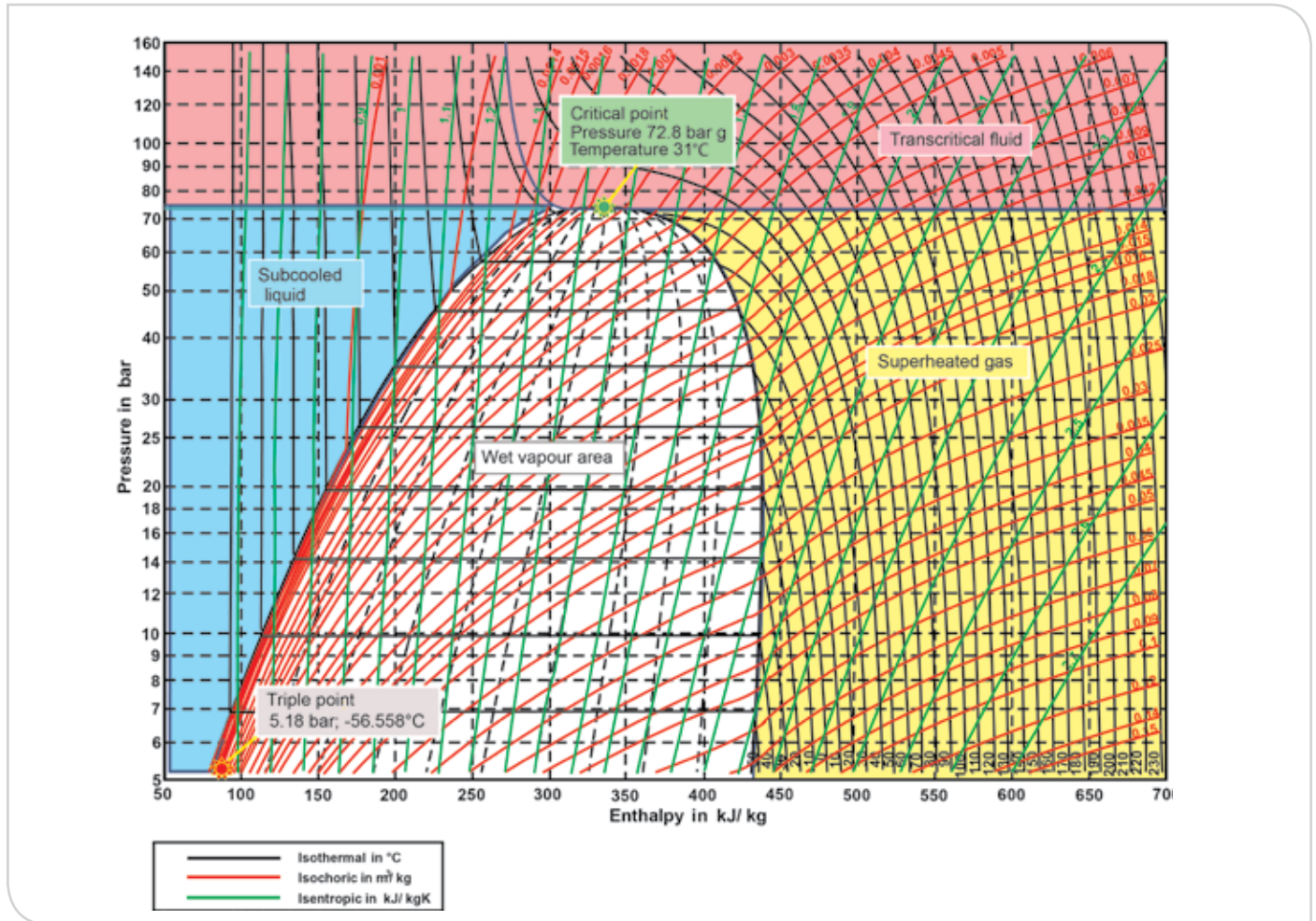

Figure 4. Pressure enthalpy chart for R744

Table 2. Basic properties of R744 compared with other refrigerants

Refrigerant	R744	HFC R404A	HFC R134a	HFC R407A	HFC R407F	HCFC R22	HFO R1234yf
	Temperature at atmospheric pressure (see information above)	-78.5°C (Temp. of the dry ice)	-46°C (Saturation temp.)	-26°C (Saturation temp.)	-41°C (Mid point saturation temp.)	-43°C (Mid point saturation temp.)	-41°C Saturation (temp.)
Critical temperature	31°C	72°C	101°C	82°C	83°C	96°C	95°C
Critical pressure	73.8 bar g	35.7 bar g	41.7 bar g	45.2 bar g	47.5 bar g	49.8 bar g	33.8 bar g
Triple-point pressure	5.2 bar	0.03 bar	0.005 bar	0.013 bar	TBC	<0.005 bar	tbc
Pressure at a saturated temperature of 20°C	57.2 bar g	10.9 bar g	5.7 bar g	10.2 bar g	10.6 bar g	9.1 bar g	5.9 bar g
Global warming potential	1 <sup>1</sup>	3922 <sup>1</sup>	1430 <sup>1</sup>	1990 <sup>2</sup>	1824 <sup>3</sup>	1700	4

<sup>1</sup>The GWP values are from the Intergovernmental Panel on Climate Change, 4th assessment report: *Climate Change 2007*

<sup>2</sup>GWP for R407A from EN378

<sup>3</sup>GWP for R407F from supplier's data

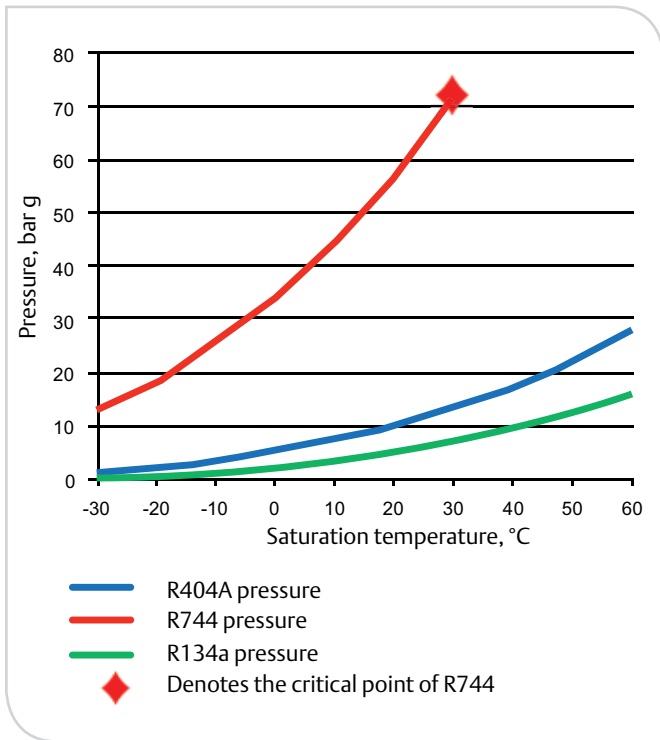

Figure 5. Pressure-temperature relationship comparison

A significant challenge with the application of CO<sub>2</sub> as a refrigerant is the higher operating pressures compared to other commercial refrigerants. The chart in figure 5 compares the pressure of R744 with R404A and R134a.

The saturation curve for R744 does not extend beyond 31°C because this is the critical point - above this condition there is no distinction between liquid and gas. Operation above this pressure is current practice in transcritical systems.

### Section 3. An Introduction to Transcritical Operation

Many R744 systems operate above the critical point some or all of the time. This is not a problem, the system just works differently.

- R744 systems work subcritical when the condensing temperature is below 31°C
- R744 systems work transcritical when the “gas cooler exit temperature” is above 31°C and the evaporating

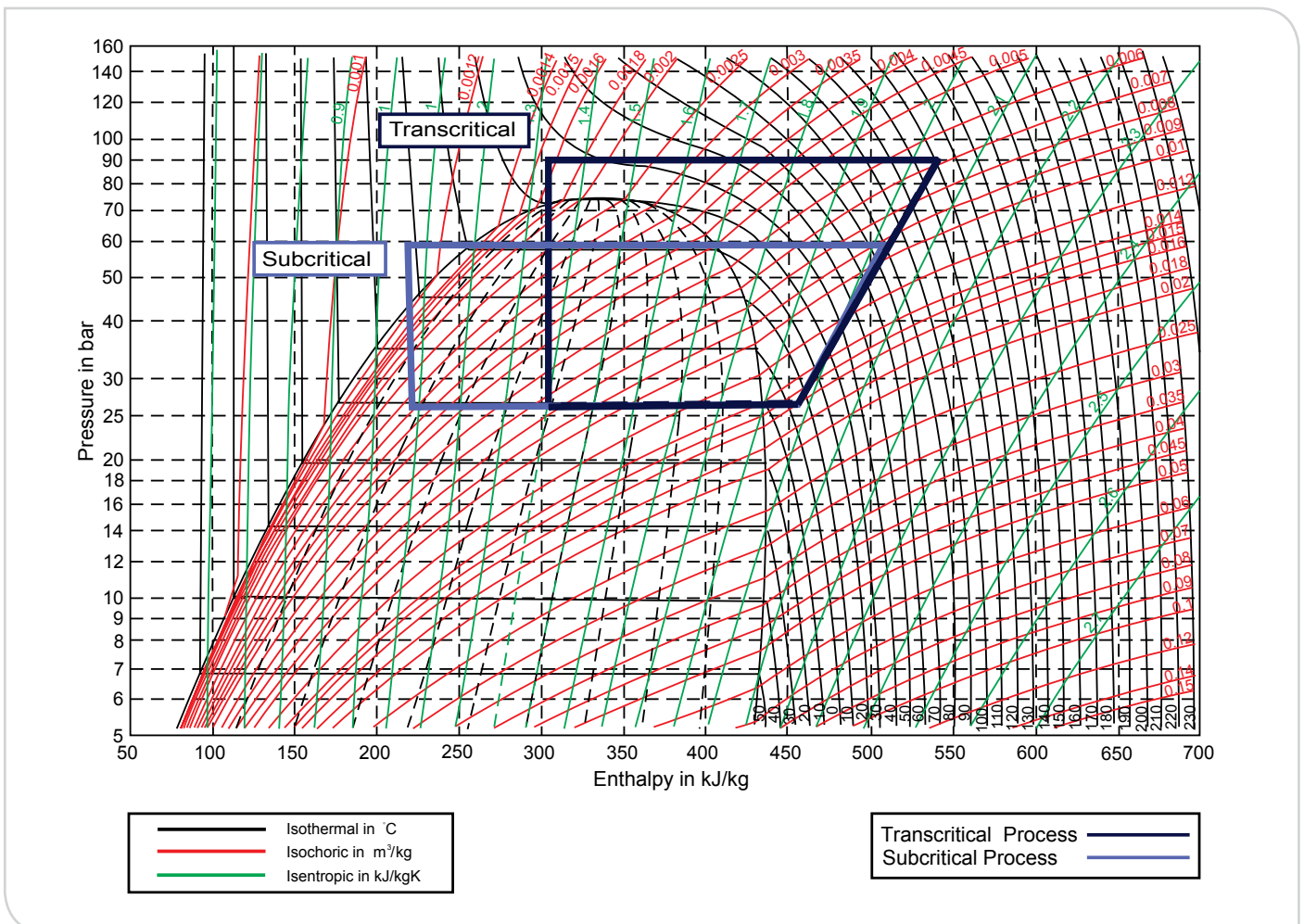

Figure 6. R744 pressure enthalpy chart showing subcritical and transcritical systems



temperature is below 31°C  
 HFC systems work always subcritical because the condensing temperature never exceeds the critical temperature (e.g., 101°C in the case of R134a).

The pressure enthalpy chart in figure 6 shows an example of a simple R744 system operating subcritically at a low ambient temperature and transcritically at a higher ambient temperature. The chart shows that the cooling capacity at the evaporator is significantly less for transcritical operation.

A capacity drop also occurs with HFC systems when the ambient temperature increases, but the change is not as great as it is with R744 when the change is from sub- to transcritical.

It is important that appropriate control of the high side (gas cooler) pressure is used to optimise the cooling capacity and efficiency when transcritical. For example, increasing the high side pressure will increase the cooling capacity. This is covered in more detail in chapter 4.

### Section 4. Behaviour in the Reference Cycle

Simple comparisons between R744 and other refrigerants can be misleading because the low critical temperature of R744 either leads to differences in system design, such as the use of cascade systems, or to transcritical operation. So like-for-like comparisons are not easy to make. The table below provides a simple theoretical comparison between R744 and common HFC refrigerants and shows the performance of ideal cycles.

Table 3. Theoretical comparison between R744 and common HFC refrigerants.

			P <sub>suc</sub>	T <sub>suc</sub>	P <sub>dis</sub>	T <sub>dis_sat</sub>	T <sub>dis</sub>	ΔH	ΔW	COP	Pressure ratio	Vol. cooling cap
			[bar abs]	[°C]	[bar abs]	[°C]	[°C]	[kJ/kg]	[kJ/kg]	[-]	[-]	[kJ/m <sup>3</sup> ]
Overview refrigerant data related to 4 different system cases												
1	R744	MT	30.47	-5	97.00	+38*	103.39	135.56	68.53	1.98	3.2	10624
	R744	LT	14.30	-30	30.47	-5	37.30	255.03	44.04	5.79	2.1	9089
2	R134a	MT	2.17	-8	10.16	+40	60.67	141.63	43.98	3.22	4.7	1496
	R744	LT	14.30	-30	30.47	-5	37.30	255.03	44.04	5.79	2.1	9089
3	R134a	MT	2.17	-8	10.16	+40	60.67	141.63	43.98	3.22	4.7	1496
	R404A	LT	1.81	-33	5.57	-3	16.74	157.28	30.99	5.08	3.1	1428
4	R134a	MT	2.17	-8	10.16	+40	60.67	141.63	43.98	3.22	4.7	1496
	R404A	LT	1.81	-33	18.30	+40	68.77	89.29	64.57	1.38	10.1	811

The four systems are:

Case:	1	2	3	4
	R744 Booster	Hybrid R744/ R134a	HFC Cascade R404A/ R134a	HFC / HFC R404A/ R134a
MT to	-5 °C	-8°C	-8 °C	-8 °C
tc	+38°C*	+40°C	+40°C	+40°C
LT to	-30 °C	-30°C	-33 °C	-33 °C
tc	-5 °C	-5°C	-3 °C	+40 °C

Superheat = 6K in all examples  
 Subcooling = 0K in all examples  
 \*gas cooler outlet temp

Compressor isentropic efficiency:

- For R744 >> 0.75
- For R404A >> 0.65
- For R134a >> 0.6

#### Legend for above table

- P<sub>suc</sub> = Suction pressure
- T<sub>suc</sub> = Suction temperature, saturated
- P<sub>dis</sub> = Discharge pressure
- T<sub>dis\_sat</sub> = Discharge temperature, saturated
- T<sub>dis</sub> = Calculated real discharge temperature
- ΔH = Enthalpie-difference through evaporator
- ΔW = Enthalpie-difference through compressor
- COP = Coefficient of performance
- Pressure ratio = Compression ratio
- Vol. cooling cap = Volumetric Cooling Capacity as ratio of evaporator enthalpy difference to the specific volume of suction gas

Assumptions:

- No suction or discharge line pressure losses
- R744 transcritical: optimum discharge pressure 97 bar

**The table highlights the following key points:**

- R744 compares reasonably well with the HFCs when subcritical and at low condensing temperatures (e.g., the LT comparison). But at higher condensing temperatures (MT example) and when transcritical (HT example), it does not compare well.
- The high suction pressure and high gas density of R744 results in very good evaporator performance. In like-for-like systems the evaporator temperature of an R744 system would, in reality, be higher than for HFC systems.
- The index of compression is very high for R744, so the discharge temperature is higher than for the HFCs. This can improve heat reclaim potential in retail systems, although the requirement for heat in the summer when the system is transcritical is limited.
- The density of R744 results in very high volumetric capacity. This reduces the required compressor displacement (but not the motor size, which would be similar to that required for HFC refrigerants).
- The required suction pipe cross section area is in proportion to the volumetric capacity. For R744 the diameter of the suction line is approximately half that required for R404A.
- The compression ratio for R744 is less than for the HFCs. This can result in higher isentropic efficiency.

**Section 5. R744 Hazards**

R744 is not flammable, but its high-pressures, toxicity at high concentration and potential for dry ice formation must be taken into account when applying and handling. This section explains some of the hazards and provides very general guidance on reducing them. More detailed information relating to the design of systems to minimise the hazards is provided later in this document.

**Asphyxiation**

R744 is odourless, heavier than air and is an asphyxiant. The practical limit<sup>1</sup> of R744 is lower than HFCs because of its potential for high toxicity (HFCs are non toxic):

- Practical limit of R744, 0.1 kg/m<sup>3</sup> (56.000 ppm);
- Practical limit of R404A, 0.48 kg/m<sup>3</sup> (120.000 ppm)

**Note** – The practical limit is defined in EN378 but may vary in regional regulations.

The table below summarises the effect of CO<sub>2</sub> at various concentrations in air.

Table 4. Effects of CO<sub>2</sub> at various concentrations in air

ppm of CO <sub>2</sub>	EFFECTS
370	Concentration in atmosphere
5.000	Long-term exposure limit (8 hours)
15.000	Short-term exposure limit (10 min)
30.000	Can be “tasted”
30.000	Discomfort, breathing difficulties, headache, dizziness, etc.
100.000	Loss of consciousness, death
300.000	Quick death

If a leak of R744 could result in a concentration exceeding the practical limit in an enclosed occupied space such as a cold room, precautions must be taken to prevent asphyxiation. These include the use of permanent leak detection which activates an alarm in the event of a leak.

**High-pressures**

System components, pipe work, tools and equipment must be rated for these pressures. It should be noted that the standstill pressure on some systems (e.g., cascade systems) is higher than the maximum rated pressure PS (hence the pressure-relief valve setting). The pressure-relief valve will discharge in the event of a fault such as a power failure.

Table 5. R744 standstill and typical system operating pressures

Standstill at 10°C ambient	44 bar g
Standstill at 30°C ambient	71.1 bar g
Low temperature evaporator (frozen food)	10 - 15 bar g
High temperature evaporator (chilled food)	25 - 30 bar g
Cascade condenser	30 - 35 bar g
Cascade high-pressure cut out (high side)	36 bar g
Cascade pressure-relief-valve (high side)	40 bar g
Transcritical high side	90 bar g
Transcritical high-pressure cut out (high side)	108 to 126 bar g
Transcritical pressure-relief valve (high side)	120 to 140 bar g

<sup>1</sup> EN378 Refrigerating systems and heat pumps – Safety and environmental requirements  
ISO 5149 mechanical refrigerating systems used for cooling and heating - Safety requirements.

To ensure the pressure does not rise to the relief pressure in the event of such a fault, these systems can be fitted with a small auxiliary cooling system. This typically runs on an auxiliary (uninterruptable) power supply and will switch on when the pressure rises above a set point (this is lower than maximum allowable suction pressure PS, but higher than the normal operating pressure). The auxiliary cooling system is sized to remove sufficient heat to keep the standstill pressure below safe low side limit when there is no load on the system (apart from heat absorbed from the ambient).

Care must be taken when charging R744 systems. The maximum operating pressure of some systems (such as cascade systems and parts of transcritical systems) is normally below the R744 cylinder pressure. These systems must be charged slowly and carefully to prevent pressure-relief valves discharging. Further information is given in Chapter 5.

### Trapped Liquid

The coefficient of expansion for R744 is significantly higher than for other refrigerants. The practical impact of this on liquid R744 trapped between closed valves is shown in the graph in figure 7:

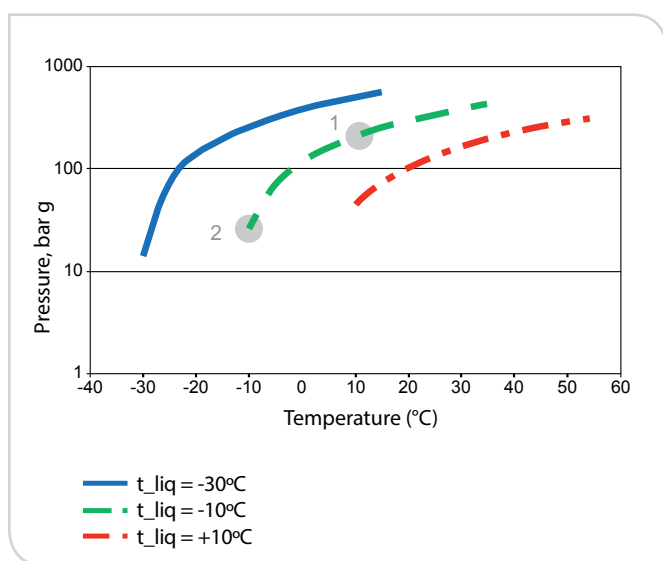

Figure 7. Relationship between temperature and pressure of trapped liquid R744. Source: Danish Technological Institute

The example shows the effect of a 20K temperature rise on liquid that is trapped at an initial temperature of -10°C. The pressure will increase from 44 bar g to approximately 240 bar g. This condition could potentially occur in a liquid line of a cascade system, and similar situations can arise in other parts of the system and in other R744 systems. As a

rule of thumb, trapped R744 liquid will increase in pressure by 10 bar for every 1K temperature increase.

The pressure of trapped liquid refrigerant always increases, but the pressure increase of R744 is much greater than for other refrigerants. This is exacerbated by the potential to trap R744 at low temperatures (LT) and hence for the liquid temperature to rise more than for other refrigerants.

Systems should be fitted with pressure-relief protection wherever liquid could be trapped, either during operation or service. Methods of providing this protection are covered in the section on design of R744 systems.

### Dry Ice

Dry ice (solid R744) is formed when R744 pressure and temperature is reduced to below the triple point (4.2 bar g, -56°C). This will not occur within a properly working refrigeration system, but can occur when:

- A pressure-relief valve discharges if it is venting vapor R744
- Venting R744 during service (component change or replacement, for example)
- Charging a system which is below 4.2 bar g (e.g., an evacuated system)

Dry ice does not expand when it is formed, but dry ice will become gas as it absorbs heat (e.g., from ambient). If the dry ice is trapped within the system, it will absorb heat from the surroundings and turn into gas. This will result in a significant pressure increase.

Dry ice can block vent lines, so care must be taken to ensure that this cannot occur:

- Appropriate pressure-relief valves should be used – see the section on system design for more information about these and how safety valves should be applied;
- When R744 is vented from a system during service it should be vented as a liquid, and the pressure in the system monitored. R744 should always be vented outside a building.

### Freeze Burns

Contact with solid or liquid R744 will cause freeze burns and should be avoided. Suitable gloves and goggles should always be worn when working with R744.

## Section 6. Comparison of R744 With Other Refrigerants

The table below shows a simple comparison of R744 with other types of refrigerant, including those that are currently commonly used and those that are currently evaluated for future use. It uses a simple “traffic light” system and employs the common HFCs, such as R404A and R134a as a baseline.

This provides a very simple introduction to the options – the situation varies globally, especially in the availability of refrigerants, components and expertise.

For retail applications a well designed and installed R407A/F system generally has better efficiency than R744 systems. However, the overall environmental performance of R744 systems is better, primarily due to the low GWP in the event of leakage. More detailed information is provided in the Emerson Climate Technologies document “Refrigerant Choices for Commercial Refrigeration<sup>8</sup>”.

Table 6. Comparison of R744 with other refrigerants

	R744	HFOs	HCs	R717
Capacity	Green	Orange	Orange	Orange
Efficiency	Orange, Red	Orange	Green	Green
Pressure	Red	Orange	Orange	Orange
Environmental impact	Green	Orange	Green	Green
Flammability	Green	Red	Red	Red
Toxicity	Orange, Red	Orange	Green	Red
Availability of refrigerant	Orange, Red	Red	Green	Green
Availability of components	Orange, Red	Orange	Green	Green
Availability of expertise	Orange, Red	Red	Orange, Red	Green
Cost of refrigerant	Green	Red	Green	Green
Cost of system	Red	Orange	Orange, Red	Red

- Refrigerant is similar to HFCs;
- Aspect of the refrigerant is worse than HFCs;
- Aspect of the refrigerant is better than HFCs.

HFO: Hydro Fluoro Olefin, e.g., R1234yf

HC: Hydro Carbon, e.g., R290

R717: Ammonia

<sup>8</sup>Reference: *Refrigerant Choices for Commercial Refrigeration* (TGE124-0910/E) available on [www.emersonclimate.eu](http://www.emersonclimate.eu)

## Section 7. Advantages and Disadvantages of R744 as a Refrigerant

R744 has the following advantages and disadvantages as a refrigerant. The list of disadvantages appears less than the advantages, but these issues should not be overlooked as

they have a significant impact on the safety and reliability of R744 systems. More information on the impact of the differences is highlighted below.

Table 7. Advantages and disadvantages of R744 as a refrigerant

Advantages	Disadvantages
<p>High refrigeration capacity due to high volumetric cooling capacity (e.g., it is approximately up to 5 times that of R404A). This has a positive impact on compressor displacement and the sizing of heat exchangers and pipe work.</p> <p>Lower pressure drops in pipe work and heat exchangers. For example, the impact of long suction and liquid lines is less.</p> <p>High heat transfer in evaporators and condensers due to the high-pressure and density. This will either allow lower temperature differences between the refrigerant and the air; therefore improving efficiency, or allow the use of smaller evaporators and condensers. Tubing wall thickness may need to be increased to handle the higher pressures, so careful design is required to take advantage of the R744 properties.</p> <p>The pressure drop across an expansion valve is greater than with other refrigerants, so the minimum setting for head pressure control can be lower. This improves efficiency.</p> <p>Lower compression ratios leading to higher compressor isentropic efficiency.</p> <p>Non-corrosive with most materials. There are very few differences to the materials used in HFC systems.</p> <p>Good miscibility with compressor lubricants for oil return. Polyolester type lubricants can continue to be used as with HFCs.</p> <p>Low toxicity and nonflammable.</p> <p>Negligible GWP so that, in the event of a leak, the direct impact on climate change is very low.</p> <p>Inexpensive to produce and widely available, although the purity of the R744 should be 99.99% for use in a refrigeration system with hermetic and semi-hermetic compressors, i.e., refrigerant grade.</p> <p>High discharge temperatures due to the high index of compression. This provides good potential for heat reclaim. Note – the discharge temperature is excessively high in transcritical systems with a large difference between evaporating and heat rejection temperatures.</p> <p>Stable molecule leading to a low potential for decomposition within the refrigeration system.</p> <p>There is no impending legislation phasing down or phasing out R744 so it can be viewed as a long-term refrigerant.</p>	<p>High operating and standstill pressures are more hazardous and increase the leak potential. Specially designed components are required.</p> <p>Special compressors are required because of the higher refrigeration capacity (different motor / displacement combination).</p> <p>R744 systems are more complex – either cascade or transcritical. This leads to higher costs in components and installation.</p> <p>Pipe working on-site potentially includes steel or stainless steel, the need for specially licensed welders, and different jointing techniques due to higher pressure and different materials.</p> <p>The greater complexity also increases the probability of poor performance and reliability, particularly if commissioning is not done well.</p> <p>For transcritical systems two stage compression is required for frozen food applications because of the high discharge temperature of R744.</p> <p>R744 transcritical systems are not suitable for high ambient areas (e.g., Southeast Asia) where the system will always run above the critical point because of the inefficiency of transcritical operation.</p> <p>R744 is not controlled by any regulation such as the European Fluorinated Gas Regulation, so its use is not as carefully monitored as HFCs and leak detection is not as rigorous. However, the high-pressures make the system leak prone, and performance will suffer if the leak rate is high.</p> <p>Very sensitive to water contamination and can form unusual compounds when there is a leak in a cascade heat exchanger.</p>

# 3 Introduction to R744 Systems

## Introduction to R744 Systems

This chapter covers general aspects of R744 systems. More detail about transcritical and cascade systems and components is given in chapter 4.

The properties of R744 effect how the refrigerant is applied (see chapter 2 for more information):

- The high density of R744 compared to HFCs results in the requirement for less compressor displacement, typically 1/5th of that needed for R404A. However the motor size would be similar since the work done is approximately the same. Smaller pipe diameters are also a result of the higher density, especially on the suction side of the system.
- The higher pressures of R744 result in the need for all components to have a higher maximum pressure rating.
- The high discharge temperatures of R744 (because of the high index of compression) result in the need for two-stage compression for LT systems that reject heat to ambient air.
- The low critical temperature of R744 results in differences in system design and control. In the retail sector this results in R744 being used mainly in the following types of system:
  - > **Transcritical systems:** Systems are called transcritical when heat rejection takes place above the critical point of the refrigerant (for CO<sub>2</sub> ambient temperatures from 20°C to 25°C). (See figure 8)
  - > **Booster systems:** Systems with two temperature levels (e.g., -35°C and -20°C evaporating temperature) and with low-stage and medium stage compressors (see figure 11).
  - > **Cascade systems:** R744 is the low-stage refrigerant in a cascade system in which the R744 is always subcritical. The heat rejected by the condensing R744 is absorbed by the evaporating high-stage refrigerant. The high-stage system is usually a conventional system using HFC or HC, in which case this is termed **hybrid cascade**. In some systems R744 is used in the high-stage as well as

the low-stage. The R744 in the low-stage is always subcritical, but in the high-stage will be transcritical at high ambient conditions.

> **Secondary systems:** The R744 is used as a secondary fluid and is pumped through the heat exchangers (cooling load). The CO<sub>2</sub> is not completely evaporated, the gas is condensed by a chiller.

The next three sections introduce transcritical, cascade and secondary systems and explain how each system works. The advantages and disadvantages of each are summarised and compared after these two sections. There is more detail about the individual components and their selection in chapter 4.

## Section 1. Introduction to Retail Transcritical Systems

The diagram in figure 8 is a simple, single stage transcritical system. The refrigerant discharged from the compressor flows into the gas cooler where heat is removed and the refrigerant temperature becomes cooler. The refrigerant is above the critical point, so it does not condense in this part of the system. The refrigerant then passes through

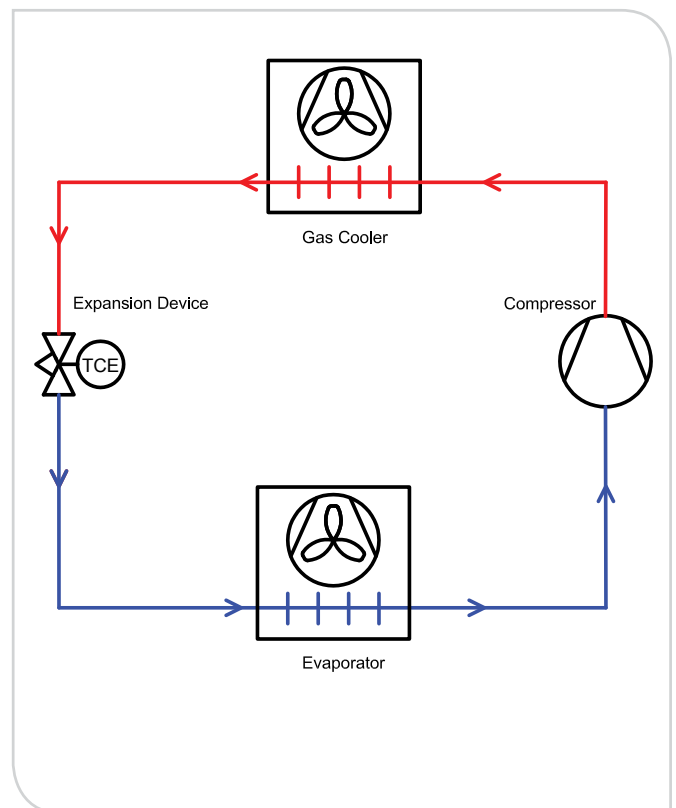

Figure 8. Simple transcritical system for medium temperature

the expansion device. The refrigerant condenses when its pressure drops below the critical point. Vapor then forms as the pressure reduces further to the evaporating pressure. The saturated refrigerant then flows into the evaporator where it evaporates and superheats as usual. The superheated gas is drawn back into the compressor.

In this simple system:

- The temperature of the refrigerant at the exit of the gas cooler depends on the size of the gas cooler
- The pressure of the refrigerant in the gas cooler depends on the quantity of refrigerant in the system and the ambient temperature

The disadvantage of this type of system is that its capacity and efficiency vary significantly with ambient (air in) temperature and with the quantity of refrigerant in the system. The simple transcritical system is shown on a pressure enthalpy chart in figure 9.

Three example systems are shown on the pressure enthalpy chart. They each have identical evaporating conditions.

In a transcritical system the R744 discharges from the compressor as a transcritical fluid because its pressure and temperature are above the critical point. In a subcritical system the refrigerant would de-superheat and then condense, rejecting heat at a constant temperature as it condenses. In a transcritical system the refrigerant does not condense – it rejects heat as a transcritical fluid and its temperature reduces during this process. (Even with a wide temperature-glide HFC such as R407A, the temperature change through the condenser is small compared to that of a gas cooler in a transcritical system.)

In each example above, the R744 exits the gas cooler at a temperature of 40°C. This exit temperature is a function of the size of the gas cooler and the ambient temperature, in the same way as condensing temperature is a function of the size of the condenser and the ambient temperature.

The cooling capacity of each system above varies significantly. For pressures below approximately 300 bar g the cooling capacity reduces as the pressure reduces. This is the opposite of what happens in a subcritical system where cooling capacity is greater at lower discharge pressures.

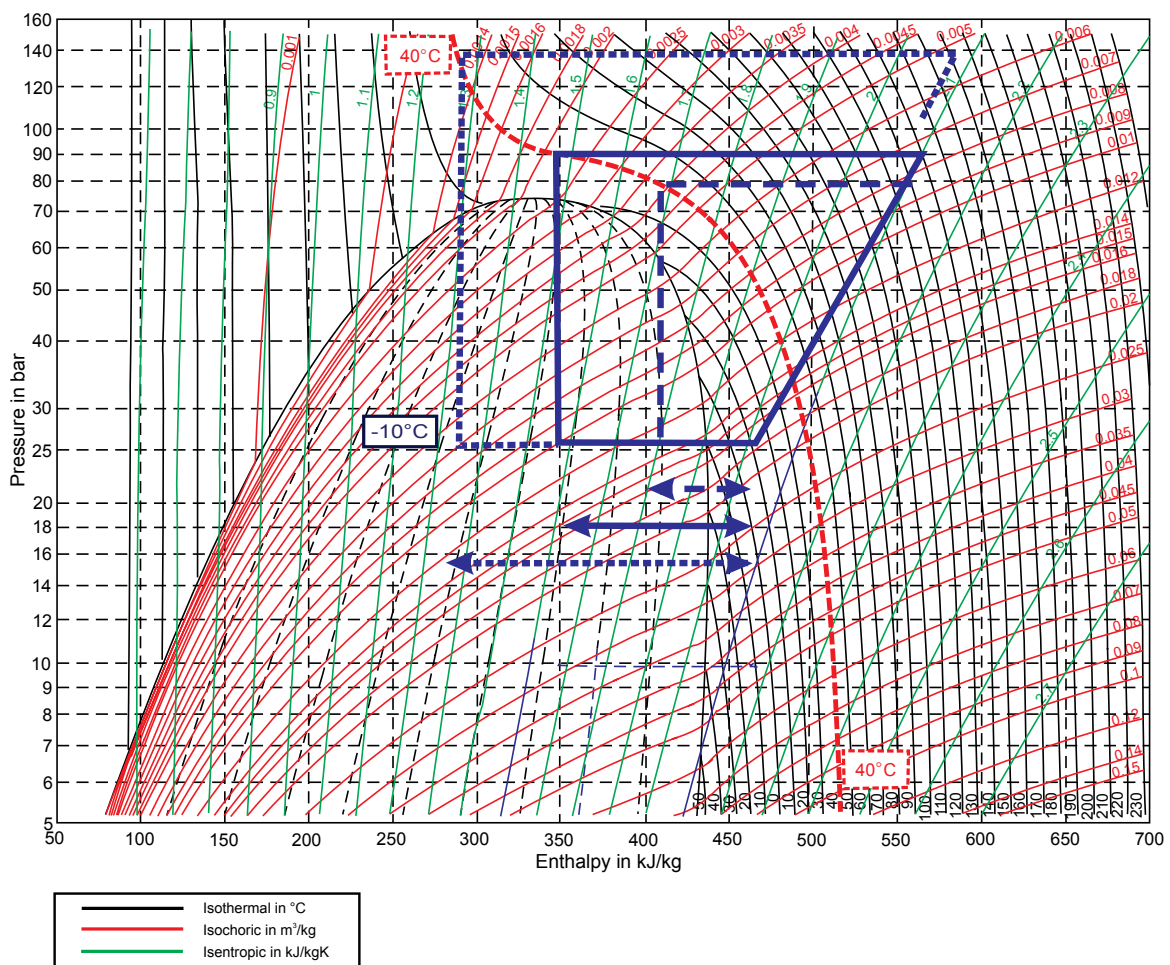

Figure 9. Pressure enthalpy chart showing transcritical operation

The compressor power input of each system also varies – the lower the pressure the lower the power input. This is the same as for a subcritical system.

The pressure enthalpy chart shows that the variation in power input is not proportional to the variation in cooling capacity. For example, increasing the head pressure from condition 1 to condition 2 provides a significant increase in cooling capacity with a very low increase in compressor power input. Increasing the pressure from condition 2 to condition 3 gives an increase in cooling capacity that is less than the increase in compressor power input.

The coefficient of performance (COP) varies widely. Unlike subcritical systems the maximum COP does not occur when the condensing pressure is at a minimum. The optimum COP depends on the evaporating conditions and gas cooler exit temperature, but is typically at a pressure between 90 and 100 bar g. In general the pressure for optimum capacity is greater than that for optimum COP.

In a retail transcritical system the gas cooler pressure is controlled to provide either optimum capacity or optimum efficiency while maintaining the pressure below the maximum allowed at all times. The simple diagram in figure 10 shows how this pressure is controlled in a typical retail system with single stage compression.

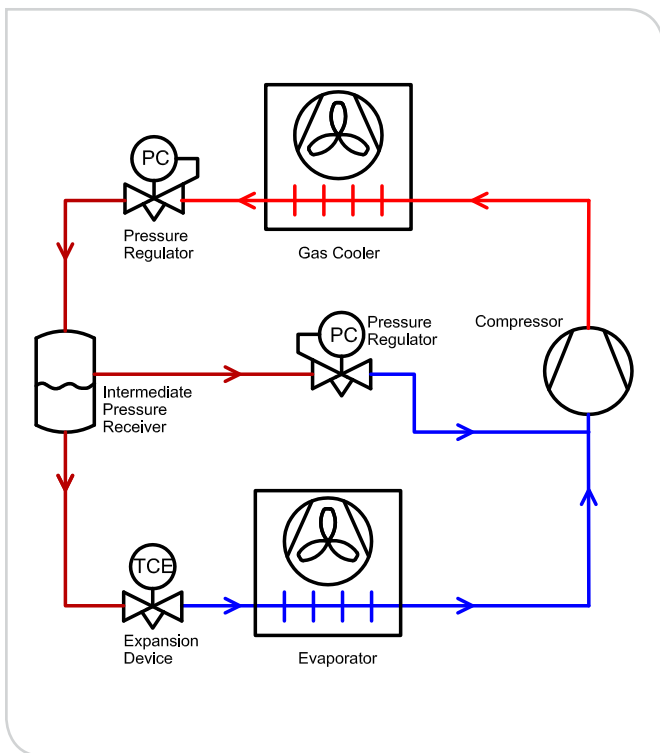

Figure 10. Simple pressure control

The two additional valves in this simple system control the gas cooler and intermediate pressures:

- The gas cooler pressure valve 1 (also called the high-pressure regulating valve) controls the pressure in the gas cooler. It is a pressure-reducing valve which is controlled from the R744 pressure in the gas cooler and its exit temperature.
- The receiver pressure valve 2 (also called the medium pressure regulating valve or the flash gas valve) controls the pressure of the refrigerant in the receiver and associated liquid distribution pipe work. It is controlled from the pressure in the receiver. Note that this receiver is also called a flash tank.

The gas cooler pressure is usually selected for optimum COP as described above, unless greater capacity is required, in which case a higher pressure would be selected to provide this while required.

### Subcritical Operation

The ambient temperature profile will determine the proportion of time a system runs in transcritical mode. For many regions a proportion of the operation will be subcritical, typically when the ambient temperature is below 20°C to 25°C. In this case the gas cooler pressure valve usually controls the refrigerant in the condenser such that it exits the condenser with a specified degree of subcooling.

### Retail Booster Systems

Two-stage compression is used for transcritical low temperature applications because the discharge temperature of R744 is high and will potentially result in lubricant break down. The diagram in figure 11 shows a simple two stage booster or externally compounded system.

The refrigerant from the low temperature loads is drawn into the low-stage compressors. The discharge from these compressors goes into the suction of the high-stage compressors.

The refrigerant from the medium temperature (MT) loads is drawn into the suction of the high-stage compressors. The refrigerant from the receiver pressure regulating valve is also drawn into the suction of the high-stage compressors. The flash gas from the receiver pressure regulating valve, and the suction gas from the medium temperature loads provide some interstage cooling. This



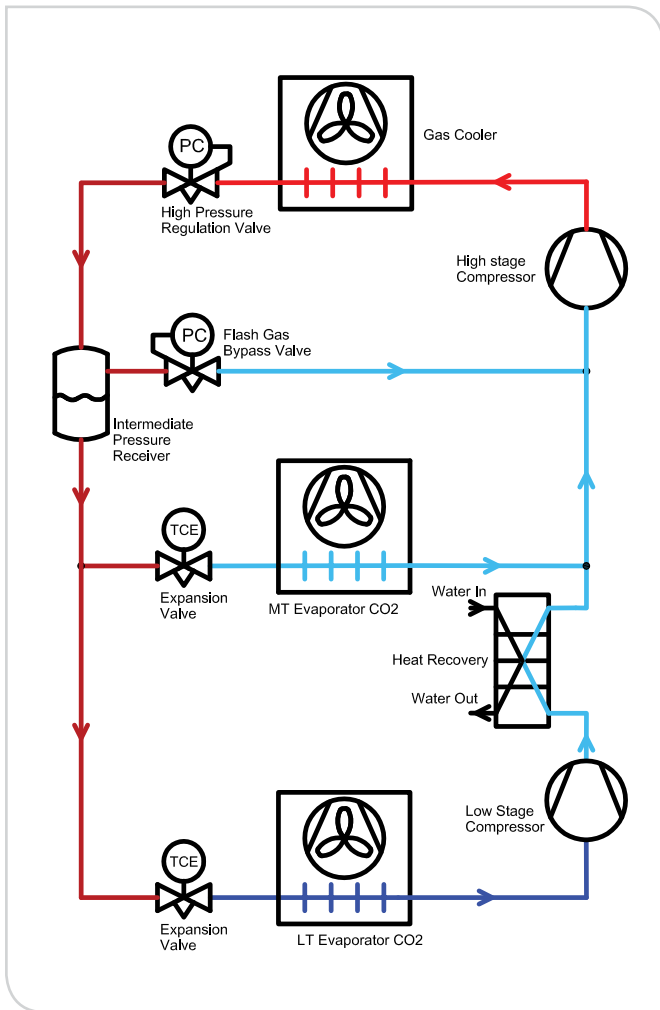

Figure 11. Simple booster system without oil management

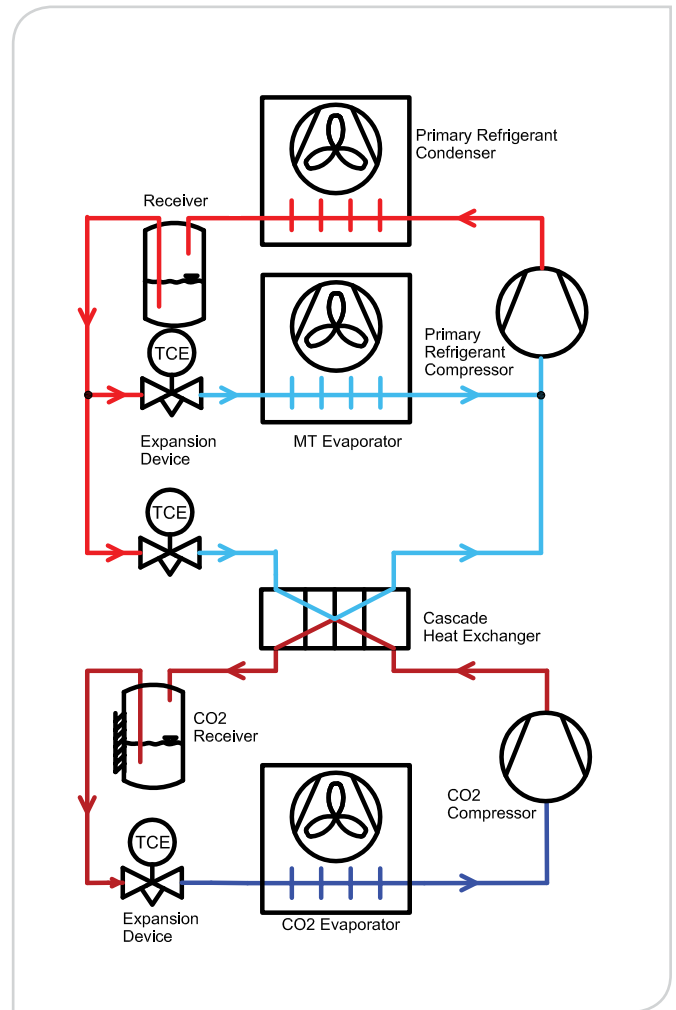

Figure 12. Simple cascade system

is usually enough to maintain the discharge temperature of the highstage compressors below the level at which the lubricant will deteriorate. Additional interstage cooling can also be provided if required.

## Section 2. Introduction to Retail Cascade Systems

The cascade system comprises:

- The low-stage, which provides the cooling for the load. It uses R744 and is always subcritical
- The high-stage, which absorbs the heat from the condensing R744 at the cascade heat exchanger

Within the cascade heat exchanger the evaporating high-stage refrigerant absorbs the heat rejected by the condensing R744. The R744 condensing temperature is maintained below the critical point. The high-stage is usually a simple, close coupled system. It is controlled by the pressure in the low-stage receiver.

In this case the high-stage provides cooling for the medium temperature load as well as removing the heat from the condensing R744 in the low-stage at the cascade heat exchanger. The high-stage refrigerant is usually an HFC or HC, in which case the cascade is a hybrid system. In some systems R744 is used in the high-stage. It will be transcritical at ambient temperatures above 20°C to 25°C – see section 1 for more information about this.

### Section 3. Secondary Systems

The diagram in figure 13 shows a simple secondary system. The high-stage system cools the liquid R744 in the secondary circuit. The R744 is pumped around the load. It is volatile, so unlike a conventional secondary fluid such as glycol it does not remain as a liquid, instead it partially evaporates. It therefore has a significantly greater cooling capacity than other secondary fluids. This reduces the pump power required and the temperature difference needed at the heat exchanger.

The R744 would typically be cooled to  $-3^{\circ}\text{C}$  for the MT load, and to  $-25^{\circ}\text{C}$  for the LT load.

The high-stage system is a simple chiller type system, typically running on an HFC or HC refrigerant.

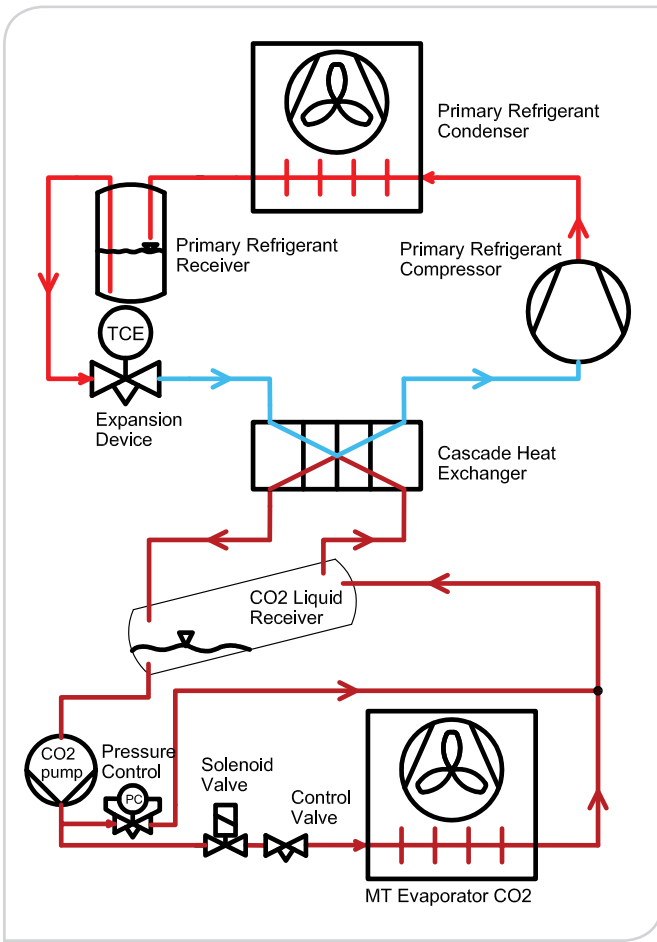

Figure 13. Simple pump system secondary

## Section 4. Selecting the Best System – Booster Versus Cascade Versus Secondary

Table 8. Advantages and disadvantages of cascade and transcritical retail systems

System	Advantages	Disadvantages
Transcritical Booster	<ul style="list-style-type: none"> <li>• One refrigerant</li> <li>• One system, lowest system costs</li> <li>• Better efficiency than HFC systems in mild climates</li> </ul>	<ul style="list-style-type: none"> <li>• LT applications require two-stage compression</li> <li>• System faults in coupled systems affect MT and LT</li> <li>• High operation pressures</li> <li>• Lower efficiency as HFC systems in warm climates</li> </ul>
Cascade	<ul style="list-style-type: none"> <li>• Two simple systems</li> <li>• LT with low R744, the MT with a low GWP HFC refrigerant</li> <li>• Standard HFC components for medium and low temperature cycles</li> <li>• Better efficiency in warm climates</li> </ul>	<ul style="list-style-type: none"> <li>• Two refrigerants although R744 can be used in the high stage</li> <li>• Temperature difference in the cascade heat exchanger reduce the efficiency slightly for the LT cycle</li> <li>• System faults in coupled systems affect MT and LT</li> </ul>
Secondary	<ul style="list-style-type: none"> <li>• Using R744 as a secondary fluid using the latent heat, very low pump power required</li> <li>• Simple chiller system for the high -stage with readily available components (separate chiller for LT and MT)</li> <li>• System works at constant pressure without any pressure pulsation</li> <li>• Option to combine LT and MT, pump circulation system for the MT using R744 combined with a LT booster system</li> <li>• Chiller could use low GWP HFCs or HCs</li> </ul>	<ul style="list-style-type: none"> <li>• Additional heat exchange and temperature difference slightly reduce the efficiency</li> <li>• R744 pumps required</li> <li>• Pumps in this size are not readily available and are unfamiliar to many refrigeration engineers</li> </ul>

The information in figures 14 and 15 are examples of comparisons between typical retail cascade, transcritical booster and secondary systems of the same cooling capacity<sup>8</sup>. In both examples the MT cooling load is 75 kW and the LT load is 18 kW:

- Base case is a transcritical booster system which uses semi-hermetic reciprocating compressors

- Case 1 is a hybrid cascade system using scroll compressors and with R744 as the low-stage and R404A as the high-stage refrigerant
- Case 2 is a secondary system using scroll and semi-hermetic reciprocating compressors and with R404A as the primary refrigerant

The factors costs and leak rates used for both examples are shown in the table in figure 16.

<sup>8</sup>Emerson Climate Technologies Calculator using default conditions

### Lifetime CO2 Emissions, Metric Tons (TEWI)

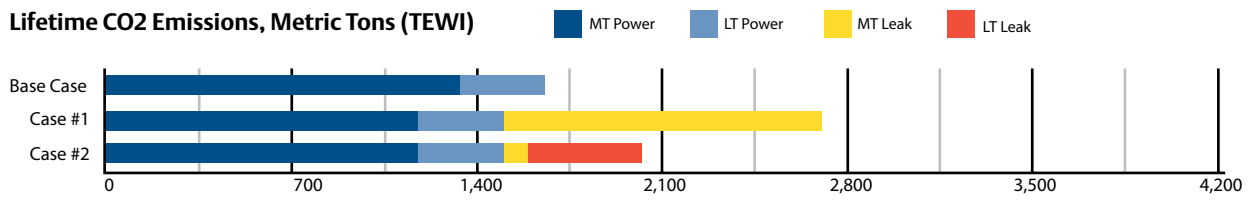

### Annual Power Cost, €

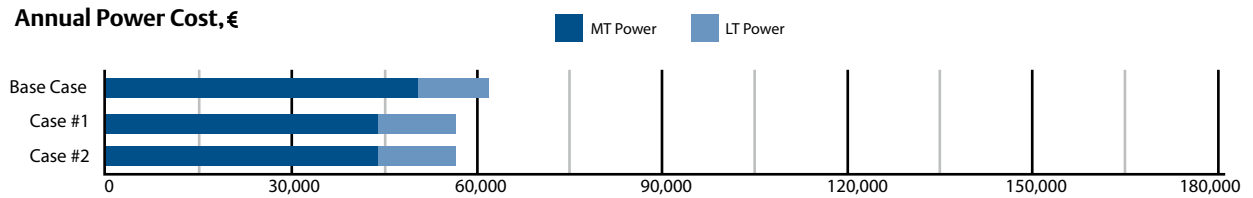

### Investment Cost, €

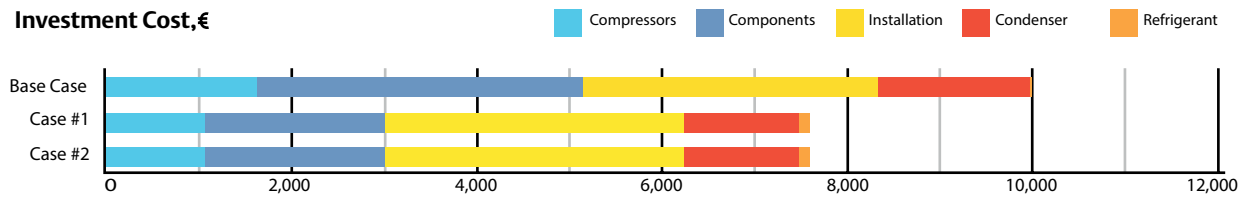
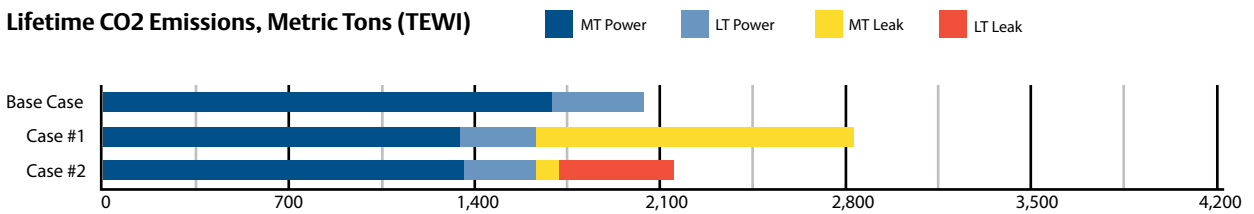
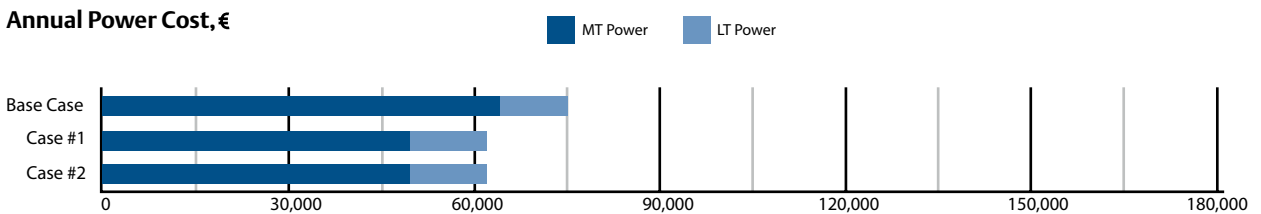

Figure 14. Comparison of system types, northern Europe

### Lifetime CO2 Emissions, Metric Tons (TEWI)



### Annual Power Cost, €



### Investment Cost, €

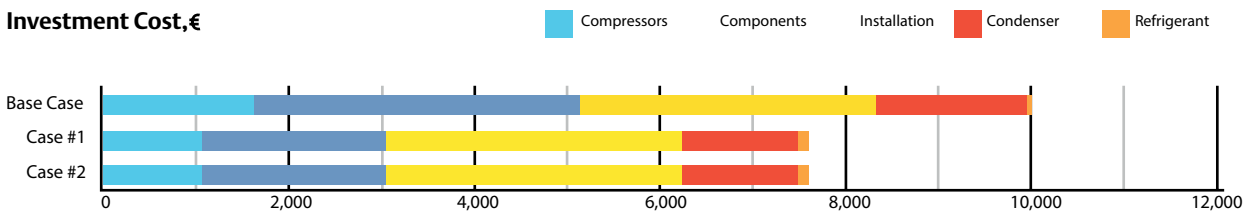

Figure 15. Comparison of system types, southern Europe

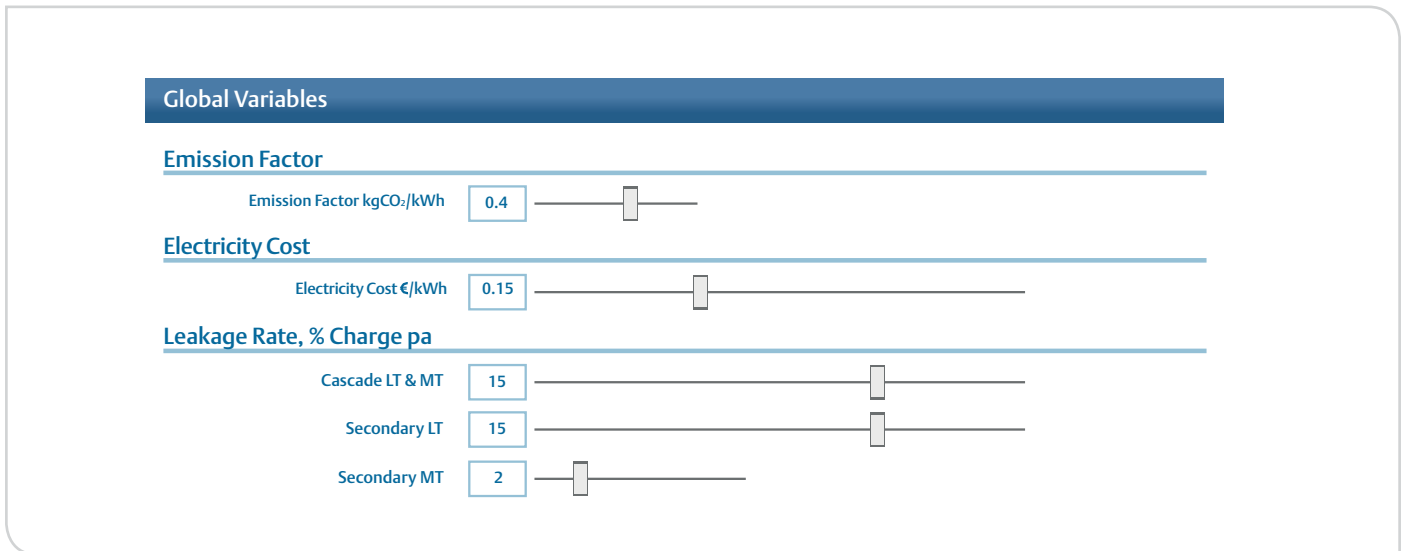

Figure 16. Variables used in comparison calculations

The energy consumption is lower for both the cascade and the secondary systems, especially in southern Europe where the ambient temperature is higher than for northern Europe. Berg /2009/ reported the results of a study to compare HFC and CO<sub>2</sub> systems in Norway. Here the investment cost was 20% higher, but all CO<sub>2</sub> systems showed better performance than the HFC systems. Because of the impact of leakage of the HFC high-stage in both cases, the overall impact on climate change is lower for the transcritical booster system. If a hydrocarbon refrigerant was used in the cascade and secondary high-stage instead of an HFC, the overall environmental impact of these systems would be less than for the transcritical system.

In conclusion, transcritical operation is generally less efficient than subcritical operation, so the selection of the system type used is usually driven by the ambient temperature profile:

- Transcritical systems are normally used in areas where the ambient temperature is generally low (i.e., predominantly below 20°C to 25°C), such as northern Europe and Canada.
- Cascade and secondary systems (subcritical R744) are usually used in high ambient areas such as southern Europe, the U.S. and much of central and South America, southeast Asia, Africa and Australia. The use of transcritical systems in high ambients generally results in low efficiency, hence cascade or secondary systems are preferred in these areas.

# 4 R744 Systems Design

## Introduction

This chapter includes more detailed information about the design of R744 cascade, transcritical booster and secondary systems. For detailed application information about Emerson R744 components refer to the Emerson document “System Product Offering”.

## Section 1. Transcritical Booster Systems

The main components of the transcritical booster system are listed in table 9 and are shown in the diagram in figure 18. The reference column in table 9 shows the reference to the component in figure 18.

## Intermediate Pressure

The intermediate pressure is selected based on the following (conflicting) requirements:

- The requirement for as low a pressure as feasible on the shop floor
- The requirement for the PS of the pipe work to be above the pressure equivalent to maximum ambient if the plant is at standstill (see section 4 for more information on standstill-pressure)

The pressure enthalpy chart in figure 17 show both intermediate pressures in systems with the same evaporating and gas cooler conditions.

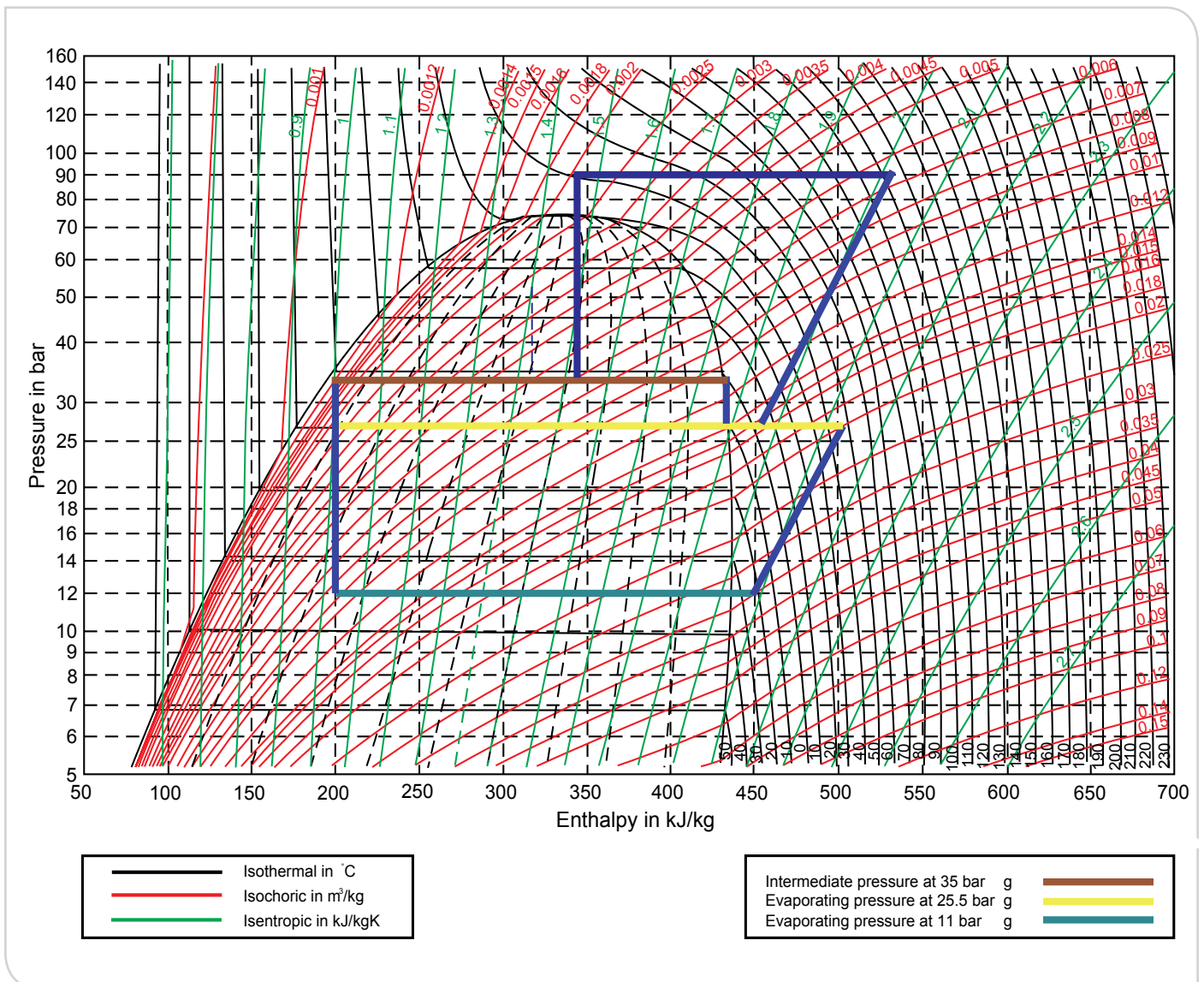

Figure 17. Pressure enthalpy chart showing two interstage conditions

Table 9. Reference table to what is shown in figure 18:

Component	Type	Ref
Low-stage compressor	Compressors that are rated for R744 are used	1
High-stage compressor	Compressors specifically designed for transcritical R744 must be used. These are usually semi-hermetic reciprocating compressors	2
Oil separator and oil return system	The oil separator and reservoir work on the same principles as a conventional oil management system (e.g., coalescent type oil separation), designed for the higher operating pressures	3
Gas cooler / condenser	Typically air-cooled, multi-fan, finned-tube type	4
Gas cooler regulating valve	A pressure-modulating valve is used, controlled from the pressure and exit temperature of the gas cooler	5
Liquid receiver (flash tank)	Standard design rated for the higher pressure	6
Receiver pressure regulating valve	A pressure modulating valve is used, controlled from the pressure in the liquid receiver (flash tank)	7
Expansion device	Electronic expansion valves are used. R410-rated valves can be used for systems with lower interstage pressure	8
Evaporator	Typically smaller diameter pipe and fewer passes are used, rated for the higher pressure	9
Others	<ul style="list-style-type: none"> <li>Pressure-relief valve: High-lift types are used to prevent blockage with dry ice, with a discharge pressure rated for R744</li> <li>Filter drier: Molecular sieve type suitable for the pressures, R410A-rated filter drier can be used for systems with lower intermediate pressure</li> <li>Switches: High-pressure and low-pressure cut-outs rated for the pressure are used</li> </ul>	

Table 10. Advantages & disadvantages of two typical intermediate pressures

Intermediate pressure	Advantages	Disadvantages
35 bar g (1°C sat temp.)	<ul style="list-style-type: none"> <li>Lower hazard in the event of a leak</li> <li>Lower potential for leakage</li> <li>Lower cost of components and pipe work</li> <li>Components and pipe work are more readily available</li> </ul>	<ul style="list-style-type: none"> <li>High potential for flash gas at the expansion valves due to low liquid temperature (i.e., sub-cooling does not occur naturally in the liquid line)</li> <li>Standstill pressure is above PS so PRVs will discharge in the event of a fault</li> </ul>
60 bar g (23°C sat temp.)	<ul style="list-style-type: none"> <li>Standstill pressure is below PS for most ambients/ store temperatures.</li> <li>Low potential for flash gas formation because the liquid temperature should be above store temperature</li> </ul>	<ul style="list-style-type: none"> <li>Higher potential for leakage</li> <li>Greater potential hazard in the event of a leak</li> <li>Higher cost of pipe work and components</li> </ul>

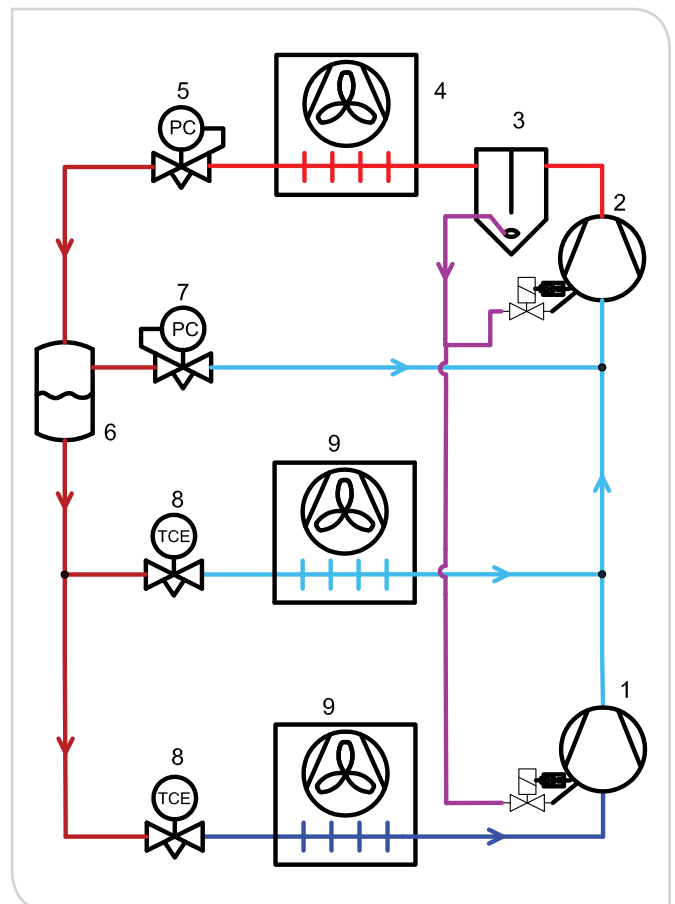

Figure 18. Typical retail transcritical booster system

There is little difference in efficiency of the two intermediate conditions because the increased enthalpy difference with the lower intermediate pressure is offset by the greater amount of flash gas produced by the increased pressure drop across the gas cooler regulating valve.

### Pipe Work Temperature

It is important to consider that with the low intermediate pressure the liquid line is below ambient temperature so there is no natural liquid subcooling. Unless there is a mechanical subcooler, the refrigerant entering the expansion valve is not subcooled, but will potentially contain flash gas. To account for this the electronic expansion valve is oversized, often by as much as 30%.

If the liquid line is below ambient temperature for most of the time it should be insulated to reduce non-useful heat gain and to prevent condensation in humid climates.

### Start up and Operation

The high-stage compressor(s) must be installed and running before the low-stage compressors can be started.

## Section 2. Cascade Systems

The R744 in the low-stage of a cascade system is designed to be subcritical during operation.

The main components of the low-stage of a cascade system are listed in the table 11 and are shown in the diagram in figure 19. The reference column in the table shows the reference to the component in figure 19.

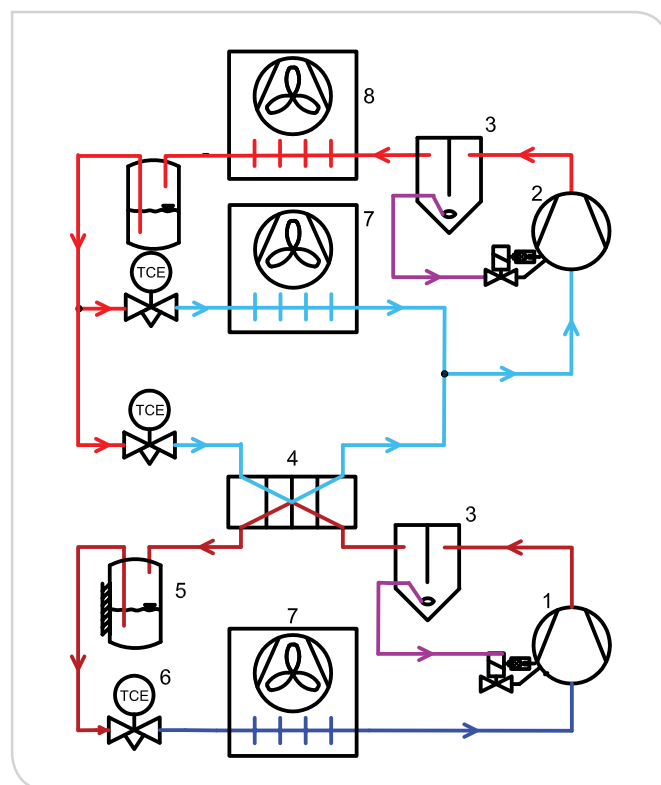

Figure 19. Typical retail cascade system

Table 11, Reference table to what is shown in figure 19

Component	Type	Ref
Low-stage compressor	Compressors that are suitable for R744 are used for low temperature	1
High-stage compressor	Compressors that are suitable for HFC/HC/Ammonia are used for medium temperature	2
Oil separator and oil return system	Components rated for R410A pressures can be used*	3
Cascade heat exchanger	Typically a plate heat exchanger or shell and tube rated for R410A *	4
Liquid receiver	Receiver rated for R410A pressures can be used *	5
Expansion device, typically EEV	Electronic Expansion Valves (EEV) are normally used, rated for R410A pressures*	6
Evaporator	Evaporators rated for R410A pressures can be used	7
Gas Cooler	Typically air-cooled, multi-fan, finned- tube type	8
Others	<ul style="list-style-type: none"> <li>De-superheater: Typically a plate heat exchanger</li> <li>Pressure-relief valve: Valves rated for R410A relief pressures can be used*</li> <li>Filter drier: Filter drier rated for R410A pressures can be used* Molecular sieve types are usually used</li> <li>Switches: High-pressure and low-pressure cut-outs rated for R410A pressures can be used*</li> </ul>	

\*If the high side PS is above 40 bar g, R410A components are not suitable, so R744 rated components are used.



## Pipe Work Temperature

Most of the R744 pipe work is below  $-5^{\circ}\text{C}$  and is therefore insulated to minimise heat gain into the refrigerant. Only the discharge line between the compressor and the cascade heat exchanger is not insulated. All the components with the exception of the R744 compressors are also insulated to reduce heat gain into the refrigerant.

The R744 liquid temperature is usually below the temperature of the surrounding ambient, so it does not subcool as it flows along the liquid line. Unless there is a mechanical sub-cooler, the refrigerant entering the expansion device at the LT load will be saturated, reducing the cooling capacity of the evaporator. The expansion device is sized to take account of the lack of subcooling – typically it will be 30% greater capacity than standard.

## The Cascade Heat Exchanger

The cascade heat exchanger (R744 condenser) is typically either a plate or a shell- and tube-type heat exchanger. The greater its capacity the lower the temperature difference between the condensing R744 and the evaporating high-stage refrigerant. This will result in better efficiency of the total system.

The cascade condenser must be located above the liquid receiver to ensure the liquid R744 flows into the receiver and does not back up in the condenser.

The R744 discharge temperature is usually high, leading to a wide temperature difference between the superheated R744 entering the cascade heat exchanger and the high-stage refrigerant leaving it. The high  $\Delta T$  can cause thermal stress and unstable operation especially in plate heat exchangers. It is beneficial to reduce the discharge line temperature of the R744 entering the cascade heat exchanger.

This can be achieved by using a de-superheater between the discharge of the R744 compressor(s) and the cascade heat exchanger. The heat reclaimed can be used, for example, for heating water. This has the added advantage of reducing the amount of heat that must be rejected at the cascade heat exchanger.

## Selection of Low-Stage Maximum Pressure (PS)

The standstill pressure of the low-stage of the cascade is usually higher than the operating pressures of both the low- and high-pressure sides of this part of the system. For example, the high side operating pressure is typically in the range 25 to 34 bar g. In an ambient temperature of  $20^{\circ}\text{C}$ , and if the high-stage system is not operating, the R744

stand-still pressure will rise to 56 bar g. This will not occur immediately because the insulation on the pipe work and components reduces the heat gain from ambient. If PS for the R744 system is selected to be below the potential maximum standstill pressure, the pressure-relief valves (PRVs) will discharge R744 if the high-stage is not operating, unless the system is designed to avoid this.

PRV discharge should be avoided where possible to reduce the associated hazard and service costs and to avoid consequential loss. It will also avoid deterioration of the PRV which can lead to leakage from the valve if it does not reseal correctly after discharge. The spring can also weaken resulting in a lower relief pressure.

For cascade systems, PS (and hence the pressure-relief valve setting) is typically 45 bar g. If the high-stage system fails or in the event of a power failure, pressure-relief valve discharge can be avoided by:

- The use of a small auxiliary condensing unit connected to an uninterruptable power supply, that removes heat from the R744 liquid receiver. Such a system will remove the heat gain from ambient into the R744 and will therefore be sufficient if the high-stage is inoperable due to power failure (in which case there will be no main heat load on the system from the evaporators). The auxiliary condensing unit will not be sufficient to maintain the low-stage system below PS if there is a load from the evaporators.
- The use of a separate pressure-relief system. This is typically a solenoid valve or ball valve that opens and relieves R744 to atmosphere at a pressure below PS but above the maximum condensing pressure. This can be achieved by the use of a transducer or high-pressure switch that opens a solenoid valve or motorised ball valve to discharge R744. The pressure does not reach PS and hence the pressure-relief valve(s) do not discharge. This does not prevent the discharge of R744, but it does reduce the probability of the pressure-relief valves venting with the associated high loss of refrigerant and potential requirement to replace the relief valves. The transducer and motorised ball valve can be run from an uninterruptable power supply so they still function in the event of a main power cut.

If PS for the low-stage system is selected to be above the maximum standstill pressure, there is no need to take the measures described above. The disadvantage of this option is that all the components in the low-stage system must be suitable for the selected PS. See section 4 for more information on standstill pressure.

## Start-up and Operating Sequence

The start up and operating sequence of a cascade system is critical. The high-stage system must be available to run before starting up or operating the low-stage system. If this is not the case the low-stage system will cut out on the high-pressure protection, and ultimately the pressure-relief valves will discharge.

## The High-Stage System

The high-stage system is usually a simple, close-coupled system with a low refrigerant charge. It has a wide range of refrigerant options and is often suitable for natural refrigerants such as Hydrocarbons or R717. The high-stage can also be R744, in which case it will be transcritical for part of the year, depending on the ambient temperature.

The high-stage system compressors are typically controlled by the pressure in the low-stage receiver (i.e., the R744 condensing temperature).

When the load reduces, the R744 receiver pressure also reduces, so the high-stage compressor capacity reduces. If the load on the R744 system increases, the receiver pressure will increase causing the high-stage compressor capacity to increase (i.e., high-stage compressors will switch on or speed up).

## Section 3. Secondary Systems

The main components in a typical retail secondary loop system are shown in the table below. The 'Ref' column in the table shows the reference to the components in figure 20.

Table 12. Reference table to what is shown in figure 20

Component	Type	Ref
Liquid pump	Typically liquid-cooled centrifugal pumps are used	1
Heat exchanger	Standard heat exchangers are used, typically plate heat exchangers	2
Receiver	A standard liquid receiver is usually used	3
Evaporator	Standard HFC evaporators are used	4
High-stage system with compressor	The high-stage system is usually a conventional chiller, operating with HFC or HC	5
Compressor	LT booster compressor	6
Other	Pressure-relief valve: Standard HFC evaporators are used	

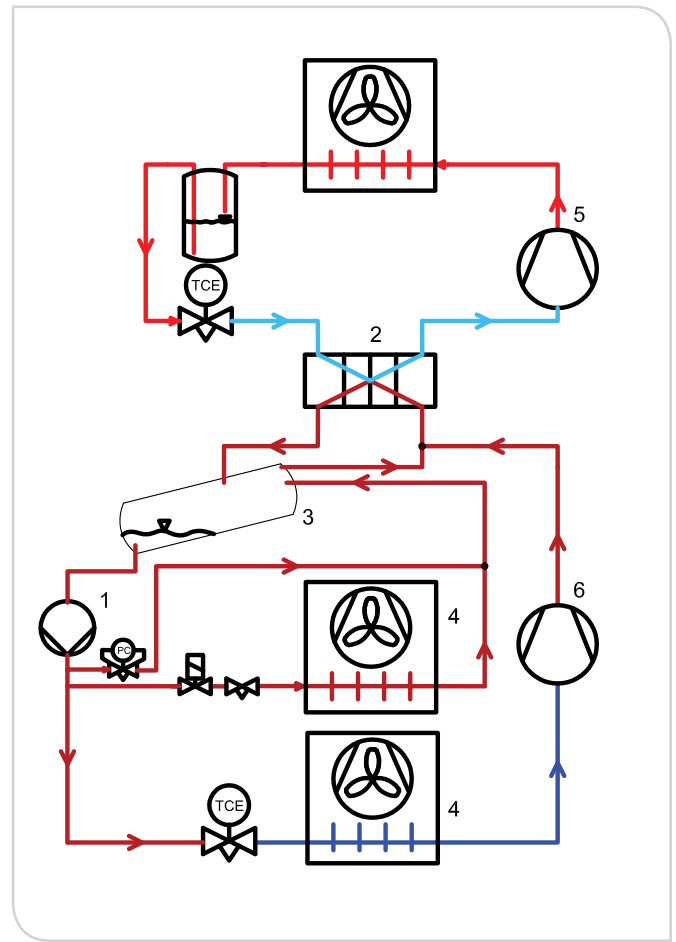

Figure 20. Combined pump circulation system for MT with LT booster system

The R744 is volatile, so some of the liquid flashes into gas as it absorbs heat in the cabinet.

The R744 vapor returning to the vessel from the load is then taken from the top of the vessel into the heat exchanger and is re-condensed.

## Liquid Pump

The liquid pump is usually a centrifugal type. It is important that pure liquid refrigerant enters the pump to avoid cavitation - flash gas in the liquid will reduce the reliability and performance of the pump. For this reason the receiver must be above the pump. Additionally, the receiver outlet is designed to avoid the formation of flash gas, for example by the incorporation of a vortex breaker (typically a baffle in the receiver outlet). This will stop vortices forming that can entrain vapor in liquid, causing cavitation at the pump.

## Pipe Work Temperature

The R744 liquid will be below ambient so the liquid pipe work must be insulated.

## Section 4. Design for Pressure

The operating and standstill pressure of the R744 systems described above are higher than for other retail refrigeration systems, although many cascade and secondary systems have similar operating pressures to the R410A systems used in the air conditioning sector. The higher pressures affect the design and specification of all system components and pipe work.

The table below shows pressures on the high side of the system for a “standard” system and a “high PS” system. High PS systems are specified to avoid the relief valve venting on standstill, when the pressure will exceed the standard pressure-relief-valve rating at ambient temperatures above 6°C (the saturation temperature equivalent to 40 bar g, see section 2 of chapter 3 for more information).

Components that are readily available for R410A systems can generally be used for subcritical systems with a PS of 45 bar g on the high side. Components that are subject to a higher PS are specifically designed for R744. More detailed information is given in the next chapter and in the Emerson document “*System Product Offering*”.

The standstill pressure is the internal pressure of the system when it is not operating. The equalized pressure depends on:

- Ambient temperature when below the critical point (for example in an ambient of 20°C the standstill pressure will be approximately 56 bar g)
- System volume and refrigerant charge when above the critical point. In this case the standstill pressure depends on the ratio refrigerant charge / system volume and is typically 120 bar g

Table 13. Typical R744 pressures in retail systems

	Typical operating pressure	PS	HP cut-out setting
<b>Transcritical booster systems</b>			
Low side, LT	13 bar g	30 bar g	27 bar g
Low side, MT / interstage pressure	25 bar g	45 bar g	40 bar g
Intermediate	35 bar g	45 bar g	40 bar g
	60 bar g	70 bar g	63 bar g
High side	90 bar g when transcritical	120 bar g	108 bar g
<b>Cascade systems</b>			
Low side, standard PS	13 bar g (LT evaporator)	30 bar g	27 bar g
Low side, high PS	13 bar g (LT evaporator)	70 bar g	63 bar g
High side, standard PS	27 bar g	45 bar g	40 bar g
High side, high PS	27 bar g	70 bar g	63 bar g
<b>Secondary systems</b>			
LT	16 bar g	30 bar g	
MT	30 bar g	45 bar g	

For many R744 systems the standstill pressure is greater than the maximum operating pressures. When this is the case systems are either:

- Designed with PS based on the maximum operating pressure, in which case the pressure-relief valves will vent when on standstill unless there is some means of reducing the pressure or
- Designed with PS based on the maximum standstill pressure

All components and assemblies must be rated for the PS of that part of the system.

Pressure-relief valves must discharge to a safe place, ideally outside a building to an unoccupied area.

When evaporators are defrosted the evaporator must be open to the suction of the system and the pack, it must not be isolated.

### Section 5. Design for Ease of Service

Systems should be designed with sufficient isolation valves to ensure access can be safely made to components and parts of the system that will require service, including:

- Liquid and suction filters, where a bypass should be fitted so the system can remain in service during replacement
- Oil separators
- Pressure-relief valves

If liquid can be trapped between valves, these sections of the system should include high-pressure protection. This can be achieved either by fitting a pressure-relief valve in that section of the system, or by installing a branch non-return valve and piping it to a section of the system which is protected by a PRV.

Gauges should be provided on the system to give an indication of each of the system pressures (see glossary for an explanation of these pressures):

- Low side: medium- and low temperature
- Intermediate on transcritical systems
- Interstage on booster systems
- High side

**These are especially important on R744 systems:**

- To reduce the need for technicians to access the system to fit gauges (specialist R744 gauges should be used where necessary)

- To avoid the risk associated with technicians fitting gauges that are not rated for the R744 pressure
- They give an indication of actual system pressure if vent lines block with dry ice

To make charging easier and safer it is advisable to install a permanent charging point in an area that is easily accessible. This avoids the need to move heavy R744 cylinders to the plant area.

If R744 cylinders are stored on site, they should be located in a gas cage, upright and secure, ideally outside a building.

### Section 6. Fixed Leak Detection

Fixed leak detection should be used if a leak of R744 can result in a dangerous concentration in the air. For example, EN378 requires leak detection to be fitted if the concentration can exceed the practical limit of 0.1 kg/m<sup>3</sup>. Typically an infrared sensor system is used, with sensors located wherever a leak can accumulate, for example in plant rooms and cold rooms. Typical alarm levels are:

- 5.000 ppm for an initial alarm
- 15.000 ppm for a main alarm

### Section 7. Cooling Capacity

The higher gas density of R744 results in a high volumetric refrigeration effect compared to all other common refrigerants. This has an effect on compressor displacement and the sizing of pipe work, evaporators and condensers.

The chart in figure 21 compares the cooling capacity of R744 with R134a and R404A for compressors with similar displacements (i.e., similar volume flow rates) in single stage systems:

- -10/ 30: -10°C evaporating temperature, 6K suction superheat, 30°C condensing temperature; no liquid subcooling
- -10/ 40: -10°C evaporating temperature, 6K suction superheat, 40°C condensing temperature for R134a and R404A, 40°C gas cooler outlet temperature and 90 bar g gas cooler pressure for R744; no liquid subcooling

The compressor power consumption for a given capacity is similar to that for HFCs, so the compressor motor/displacement combination is different for R744.

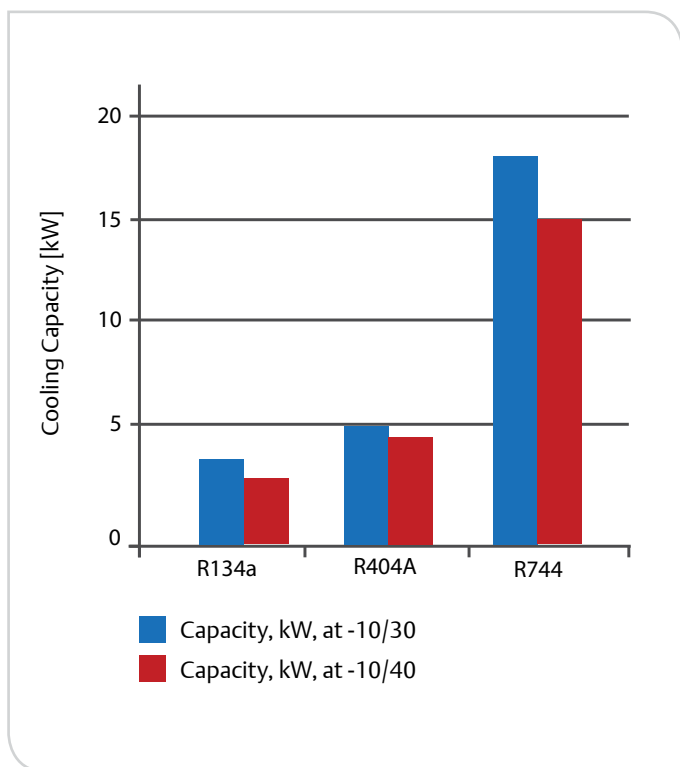

Figure 21, Comparison of HFC and R744 capacities in typical systems

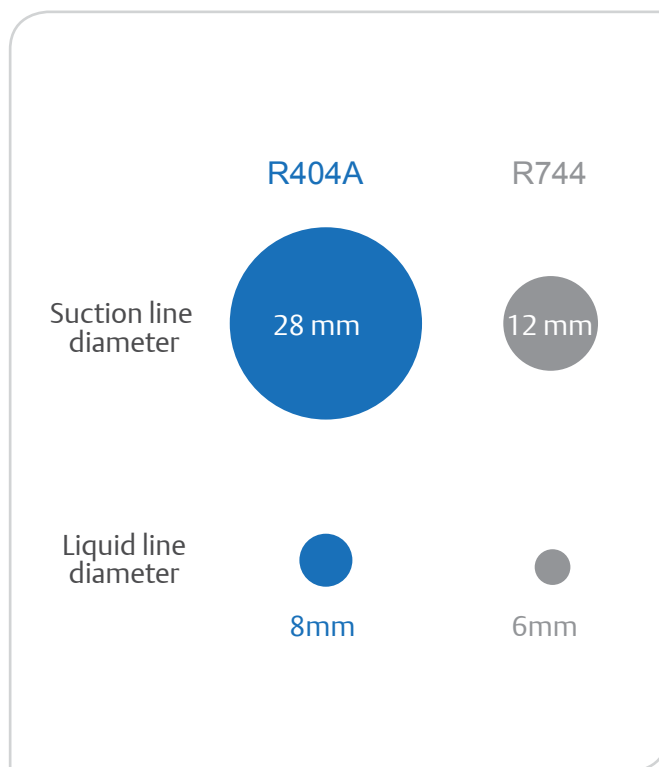

Figure 22, Comparison of pipe sizes for typical systems

## Section 8. Capacity Modulation

An R744 retail system will typically use fewer compressors than an HFC system of the same cooling capacity. This is because the higher capacity of R744 reduces the total compressor displacement required. Heat exchangers are often smaller, leading to more rapid changes in operating conditions when the load changes. Both these factors increase the need for effective capacity control to meet a varying load.

## Section 9. Pipe Work and Jointing

The refrigerant properties which reduce the required compressor displacement also allow smaller diameter pipe work to be used. This is especially true in the suction line carrying superheated gas. The effect on liquid line size is lower because the liquid volume flow is similar to HFCs. The chart in figure 22 shows one example of the difference in pipe sizing.

The heat transfer coefficient of boiling R744 is greater than for HFC refrigerants. This will improve the performance of evaporators and condensers, which will allow either:

- The same sized evaporators and condensers to be used compared to HFCs, with greater heat transfer capability and hence lower TDs. This will improve energy efficiency
- Smaller evaporators and condensers to be used (e.g., smaller diameter pipe and fewer passes). This will reduce the component cost and space required

The pressure drop in R744 pipe work and components is generally lower than with HFCs (especially in suction lines), and the system performance is less sensitive to pressure drop. The system designer can therefore allow for a greater pressure drop. In general refrigerant velocities are similar to those for HFC refrigerants.

The general rules of good pipe design should also be followed with R744 systems. Pipe thickness will usually be greater because of the higher pressures, and in some cases steel will be used in place of copper. As explained above, smaller diameter pipe is used in some parts of the system. This will inherently withstand higher pressures than larger diameter pipe of the same wall thickness. Table 14 shows the maximum pressure of a range of copper tube, calculated using EN14276-2:2007 and EN13480-3:2002.

Table 14. Maximum pressure of a range of copper tube, calculated using EN14276-2:2007 and EN13480-3:2002

Standard Wire Gauge	22	20	18	16	14	12	10
Thickness, mm	0.711	0.914	1.219	1.626	2.032	2.642	3.251
OD, in	Maximum pressure in bar (relative)						
1/4	131	174					
3/8		129	179				
1/2		81	111	153			
5/8		59	87	119	162		
3/4		49	71	98	124	166	
7/8		41	56	82	105	140	
1 1/8			43	58	80	106	133
1 3/8				47	60	85	107
1 5/8					50	71	89

The most reliable method of jointing copper tube is brazing. The greater thickness reduces the opportunity to swage the pipe and therefore increases the use of fittings. In addition, the heat required for a brazed joint is greater to get the required degree of penetration.

Copper tube is available specifically for use on R744 systems with a PS of 120 bar g (known by the trade name K65 tube).

The material comprises copper with 2.4% ferrous plus very small amounts of zinc and phosphorous. It cannot be bent or swaged, so is joined using proprietary brazed fittings.

Steel pipe will withstand a greater pressure than copper tube, as shown in table 15 for Grade 40 steel.

Table 15. Steel pipe withstands a greater pressure than copper tube

1/4"	3/8"	1/2"	3/4"	1"	1 1/4"	1 1/2"	2"	2 1/2"	3"
444	357	342	277	259	213	191	161	177	153

Piping should be adequately supported and clamped. Pipe supports should be closer than for other refrigerants due to the higher density of R744 and therefore weight of refrigerant in pipes. The following tables provide guidance on this.

Table 16a, Copper pipe sizes and their maximum spacing of supports

Copper pipe sizes O.D.		Maximum spacing of supports	
(mm)	(in)	(m)	(ft)
10 - 19	3/8 - 3/4	1	3.3
22 - 54	7/8 - 2 1/8	2	6.6
67 - 80	2 5/8 - 3 1/8	3	9.9

Table 16b, Steel pipe sizes and their maximum spacing of supports

Steel pipe sizes nominal bore		Maximum spacing of supports	
(mm)	(in)	(m)	(ft)
15 - 25	1/2 - 1	1	3.5
32 - 50	1 1/4 - 2	3	10
65 - 80	2 1/3 - 3	3.5	12
100 - 175	4 - 7	4	14
200 - 350	8 - 14	6	20
400 - 450	16 - 18	7.5	25

Source: UK Institute of Refrigeration Safety Code of Practice for Refrigerating Systems Utilising

## Section 10. Lubricants and Oil Return

Polyolester (POE) lubricants have good miscibility with R744 and are predominantly used as compressor lubricants in retail R744 systems. Because of the high solubility, higher viscosity lubricants are used when compared to those used with HFCs. This reduces the effect of oil dilution by refrigerant and therefore maintains the lubricant properties.

POE oils are very hygroscopic (i.e., they readily absorb moisture), so care must be taken to ensure moisture does not enter the system:

- The lubricant must not be exposed to air, and oil containers must be sealed except when the oil is being dispensed
- Components such as the compressor must also be sealed, except when work is actually being performed
- The evacuation process must be effective
- Replacement drier cores must be fitted whenever the system is open and exposed to air

R744 liquid is heavier than oil, as is the case with HFC refrigerants. Effective oil separation and return to the compressor is necessary on retail systems. Typically this is best achieved by the use of coalescent-type oil separators and, for multiple compressors, a conventional oil-return system.

## Section 11. Materials

R744 is compatible with most material used in retail refrigeration systems. Elastomers must be carefully

selected as R744 penetrates the material more than other refrigerants would. When seals made of these materials are depressurised, the absorbed R744 rapidly evaporates causing explosive decompression and damage to the seal. Some seal materials swell and soften with R744.

Steel pipe work is often used in R744 systems because of the high-pressures, especially in discharge lines and headers. Steel can become brittle at low temperatures. In the event of a leak the temperature can reduce to near  $-78^{\circ}\text{C}$ , so low temperature steel must be used.

## Section 12. Potential for Heat Reclaim

The discharge temperature of an R744 system is higher than for HFC systems running at similar evaporating and ambient temperatures. This provides more potential for the reclaim of heat at a useful temperature.

Additionally, when the refrigerant is transcritical its temperature in the gas cooler reduces throughout the heat exchange process – all heat rejection occurs at a changing temperature. This is an advantage over a subcritical condenser where the refrigerant temperature reduces only as it de-superheats, and this is for a small part of the process. It then remains at a constant temperature (the condensing temperature) as it condenses. The majority of the heat rejection occurs at constant temperature.

The charts in figure 23 illustrate this point and compare an R134a system to an R744 transcritical system. It can be seen that the final media temperature can be significantly higher for the R744 system.

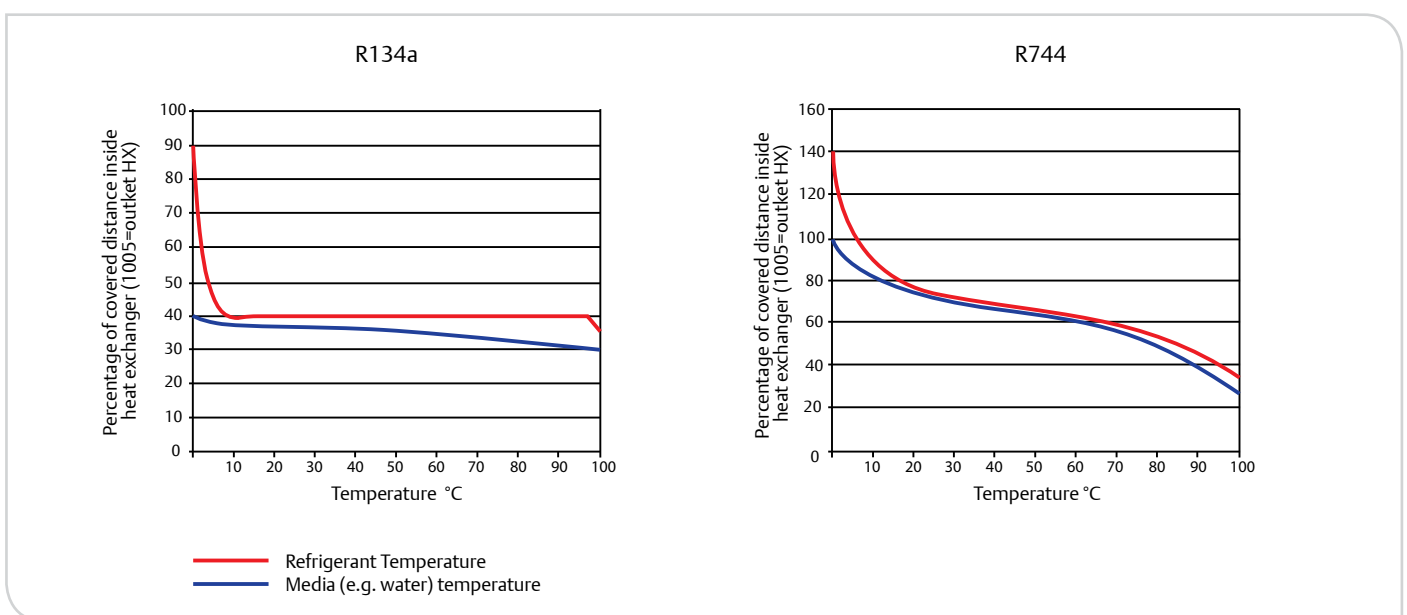

Figure 23. Heat Reclaim comparison of R134a system to R744 transcritical system

# 5 R744 Systems: Installation, Commissioning and Services

## Introduction

This chapter covers some of the key points when systems are commissioned and operating, and important service and maintenance issues. This chapter is not a complete guide to commissioning and service.

Technicians installing, commissioning, servicing and maintaining R744 systems must be trained in the safe handling of this refrigerant before working on these systems. Key points about the hazards of R744 must be taken into account when working on these systems:

- System and cylinder pressures are high, e.g., approximately 50 bar g at 15°C
- R744 is an asphyxiant (the practical limit in EN378 is 0.1 kg/m<sup>3</sup>)
- There is a high risk of freeze burns from liquid or solid R744
- There is a high risk of excessive pressure with trapped liquid or gas; 1°C increase in temperature produces 10 bar increase in pressure
- There is a risk of solid R744 formation when venting liquid or charging liquid into an evacuated system
- R744 (refrigerant-grade CO<sub>2</sub>) must be used to ensure low levels of moisture
- Appropriate personal protective equipment, including gloves and goggles, must be worn
- R744 cylinders are heavy, so care is needed. They must be secured when handling. Unsecured they can move when opened
- The correct cylinder adaptors must be used – connections must not be bodged
- R744 rated equipment for charging and venting must be used. Standard gauge manifold hoses must not be used

- The correct case and plant isolation procedures must be followed to avoid trapping liquid in service lines, pipe work or components
- Systems must not be brazed or welded with R744 still in the system / part of system

## Section 1. Good Installation Practice

Sufficient time should be provided so that systems can be fully pressure tested for strength and leak tightness prior to being put into service. This avoids future issues associated with reliability.

### Pipe Work

Pipe work should be routed in accordance with good refrigeration practice, to minimise pressure drop and allow oil return to the compressor. It is important that pipe work is correctly supported and fixed as outlined in chapter 3.

A pipe which is not correctly fixed will whip at high speed if the pipe or joint ruptures, potentially causing injury or fatality.

Vent lines from pressure-relief valves should discharge refrigerant to a safe place. This is typically to an unoccupied area outside a building or plant enclosure, to where the refrigerant will disperse without risk of asphyxiation. The PRV vent lines should be of sufficient diameter to prevent R744 solidifying and blocking the vent line itself.

The most reliable method of jointing pipe work is to braze or weld. It is advised for all joints that welders and brazers are approved to a nationally recognised standard. Special attention should be made to the hazard category of the joint and the required levels of competency and certification to carry out the brazing or welding. Mechanical joints should be avoided where possible. If they are used the fittings must be rated for the pressure and the jointing procedure specified by the manufacturer must be followed.

Table 17. Pipe diameters for copper and steel pipes

Copper pipe OD mm / inches	Maximum support spacing m	Steel pipe nominal bore mm / inches	Maximum support spacing m
10 – 19 / 3/8 to 3/4	1	15 – 25 / 1/2 - 1	1
22 – 54 / 7/8 to 2 1/8	2	32 – 50 / 1 1/4 - 2	3
67 – 80 / 2 5/8 to 3 1/8	3	65 – 80 / 2 1/2 - 3	3.5
		100 - 175 / 4 - 7	4



## Pressure Testing

The completed installation should be pressure tested for strength and leak tightness in accordance with the relevant standard. This is typically:

- Strength test at 1.1 x PS for most of the pipe work (i.e., joints which are hazard category 1 or lower<sup>11</sup>)
- Strength test at 1.43 x PS for the high side of transcritical systems where the hazard category is 2 or higher. Alternatively 1.1 x PS can be used, in which case 10% of the joints must be non-destructively tested
- Leak tightness test at 1.0 x PS.

The relevant standard (such as EN378-2:2008) must be referred to for specific pressure testing requirements. Components and assemblies such as compressors and packs do not usually need to be pressure tested onsite as they have already been tested by the manufacturer.

Pressure-relief-valves should be isolated during pressure testing. Good practice should be followed when pressure testing:

- Equipment, including the nitrogen regulator, should be rated for the pressure, an example is shown in figure 24
- The area must be evacuated of anyone not directly involved in the pressure testing
- Oxygen free nitrogen should be charged slowly into the system and an initial check carried out at approximately 5 bar g
- The strength test pressure should be held for a minimum of 15 minutes
- The nitrogen used for leak testing should be vented to a well-ventilated area, ideally outside
- The pressure should be reduced to the tightness test pressure and each joint checked with leak detection spray, or the pressure held and monitored over at least 24 hours

## Evacuation

Systems must be thoroughly evacuated to remove non-condensable gases and moisture – both will have an adverse impact on R744 systems.

Non-condensable gases such as air and nitrogen tend to accumulate in the condenser or gas cooler, where they cause an increase in pressure. This leads to a reduction in capacity, efficiency and reliability of the system. The effect of non-condensable gases in an R744 system is greater compared to HFC systems, especially transcritical systems.

High moisture content will result in system failures, for example, water and carbon dioxide produce carbonic acid.

Table 18. Maximum solubility of moisture in R744

R744 state	Temperature	Maximum ppm moisture
Liquid	-40°C	130
	-10°C	405
Vapor	-40°C	7
	-10°C	33



Figure 24. Example of regulator suitable for pressure testing transcritical R744 systems

<sup>11</sup>As defined in EN378-2. annex B

If the moisture content is above the maximum ppm as shown in table 18, there will be free moisture that can freeze. This is most likely in the superheated vapor between the exit of the evaporator and compressor suction, especially with LT evaporators. If moisture is allowed to accumulate in a static part of the system it can freeze and expand, causing pipe failure.

Great care should be taken during any service procedures to minimise the ingress of air and moisture to avoid the problems highlighted above.

## Section 2. Charging R744

R744 is available in cylinders with either a liquid take-off or a gas take-off valve and is also available in bulk. The cylinders are heavier than other refrigerant cylinders, so care is needed when handling them – for example, they should be moved on a trolley. They are generally less stable than other refrigerant cylinders because of their diameter to height ratio, so they should be secured when in use and when they are stored or transported.

The equipment used to connect the cylinder to the system must be rated for the pressure. For example, EN378 specifies that equipment must be rated for at least 90 bar g. Typically hydraulic hose or braided steel hose is used – an example is shown in figure 25.



Figure 25. Example of R744 charging equipment

The connection to the cylinder must be the correct fitting for the cylinder valve – a standard adaptor for an HFC cylinder must not be used.

All charging lines should be evacuated or purged prior to charging to reduce the ingress of air and moisture into the system.

To prevent dry ice formation, the evacuated system should be charged with R744 vapor to a pressure above the triple point (4.2 bar g). The whole system must be above the triple point – this is likely to be the case if all the gauges show a pressure of 10 bar g. When this is achieved the system can then be charged with liquid.

Care must be taken when charging R744 systems to ensure pressure-relief valves do not discharge. The R744 cylinder pressure will be greater than some or all of the PRV relief pressures, especially those on the low-stage of cascade systems and the low and intermediate sides of transcritical booster systems. To avoid PRV discharge the refrigerant should be charged slowly to allow system pressure to equalise, especially during initial bulk charging (“bomb” charging) of the system.

### Charging the Low-Stage of Cascade Systems

Before the low-stage of a cascade system is charged, the high-stage must be available to run. So the high-stage must be charged and commissioned before the low-stage is charged.

### Charging a Transcritical Booster System

It is unlikely that all of the refrigerant will be able to be charged without running the system. The system should not be topped up by charging into the suction. Systems with an intermediate pressure that is higher than the cylinder pressure should be pumped down or the intermediate pressure reduced to enable refrigerant to be charged. Alternatively, the cylinder pressure can be increased by heating the cylinder with a thermostatically controlled heater.

The high-stage compressors must be available to operate before the low-stage compressors can be started.

## Section 3. System Checks

Before the system is operated for the first time, the following should be checked:

## All Systems:

- Visual inspection
- Documentation for the system and its marking, especially with regard to pressure equipment
- Installation of the safety devices
- Control tests to ensure all controls function correctly, including high, low and oil-pressure cut-outs, interlocks, transducers and control devices. This should include any manual back up system
- Set pressure of all safety devices and other pressure cut-outs
- Set pressure of the gas cooler pressure regulating valve
- Compressor and oil reservoir oil levels
- Cores are fitted in the filter driers
- The pressure test records
- All valves are open / closed as required to operate the system

During initial operation the following should also be checked:

- Phase rotation of scroll compressors
- Fan rotation; check before starting compressors – turn fans on manually
- Refrigerant level
- Oil level in compressors and oil reservoir
- Expansion valve superheat
- Pressure and temperature of the cascade heat exchanger
- Regulating valve in both subcritical and transcritical mode
- Operating pressure of the receiver pressure regulating valve
- Operation of any auxiliary cooling unit

## Section 4. Service

### General

Work should be carried out in a well-ventilated area. If there is no operational permanent leak detection, the technician should use a personal R744 detector to ensure the area is safe to work in. Appropriate personal protective equipment, including gloves, safety glasses and ear protectors should be used. Tools and equipment such as hoses should be rated for the pressure of the system, R744 cylinder and nitrogen cylinder where used.

Care should be taken when accessing the system – the technician should be familiar with the system and should understand how sections of the system are safely isolated.

This includes the effect on the system of closing valves and the potential for trapping liquid R744 between closed valves.

### Leak Detection

R744 systems can have a high leak potential because of the higher pressures and smaller molecule size. Retail R744 central plant systems have a high number of joints which further increases leak potential. Leakage is hazardous and increases the energy consumption of the system. So although R744 has a very low global warming potential, leak detection is critical.

Leaks can be detected using the following methods:

- Visual inspection – many leaks result in oil stains on and around the system
- Leak detection spray, although this is difficult on insulated joints and sections of the installation below 0°C
- Hand held electronic leak detector suitable for R744, typically using infrared technology, an example is shown in figure 26
- Ultrasonic leak detector



Figure 26. Example of an electronic leak detector suitable for R744

Leak detection should be methodical and the whole system checked. Leaks should be repaired as soon as possible after detection. To maintain energy efficiency it is recommended that retail R744 systems are checked for leaks following, at a minimum, the same regimen as specified in the European Fluorinated Gas Regulation<sup>12</sup> for HFC refrigerants, as shown in table 19:

Table 19. F-gas regulation leak check

Charge size, kg CO <sub>2</sub>	Frequency of leak detection
Up to 30	1 / year
30 to 300	2 / year
More than 300	4 / year

<sup>12</sup> Regulation 842/2006 on certain fluorinated greenhouse gases

## Disposal of R744

R744 is usually vented from systems rather than being recovered. It is important it is safely vented to a well-ventilated area, ideally to outside a building. It is an asphyxiant with low toxicity.

Dry ice can form in the vent line or in the system as the pressure drops through the triple-point pressure (4.2 bar g) to atmospheric pressure. This can give a false indication that the system is devoid of refrigerant – if dry ice forms the refrigerant pressure will drop to 0 bar g. When the dry ice sublimates the pressure will increase, for example to 56 bar g if the temperature is 20°C.

If R744 is recovered, the recovery machine, cylinder and any associated equipment must be rated for the maximum pressure. This would be 70 bar g in an ambient of 30°C for example, but could be significantly higher if the ambient is greater. Most recovery machines and cylinders are not rated for the required pressure.

## Isolation of Components for Service

When isolating components for service care must be taken to ensure R744 liquid is not trapped between closed valves in an unprotected part of the system. Control valves should not be used as isolation valves. Welding or brazing should not be carried out on the

system until the R744 has been removed. Care should be taken when removing flanges to ensure all the R744 has been removed and the pressure is as low as possible:

- All bolts should be slackened
- The flange should be loosened with at least two bolts still in place

There are various methods of removing the R744:

- It can be vented as described above
- It can be transferred to another part of the system
- It can be evaporated as described below

The procedure below is an example for isolating the evaporator in a cabinet and is from *The British Refrigeration Association's Code of Practice for Isolation of a Display Cabinet Evaporator from a Carbon Dioxide (R744) System*. The example in figure 27 shows a typical arrangement of isolation valves.

1. Mount a gauge to the access port on the ball valve (B)
2. Isolate the inlet ball valve (A) while the control valve (C) is open. Ensure the control valve is open using a permanent magnet
3. Allow the coil to pump out for 15 minutes
4. Isolate the evaporator coil outlet ball valve (B)
5. Immediately proceed to vent refrigerant from the access port A while the pressure is being observed on the gauge

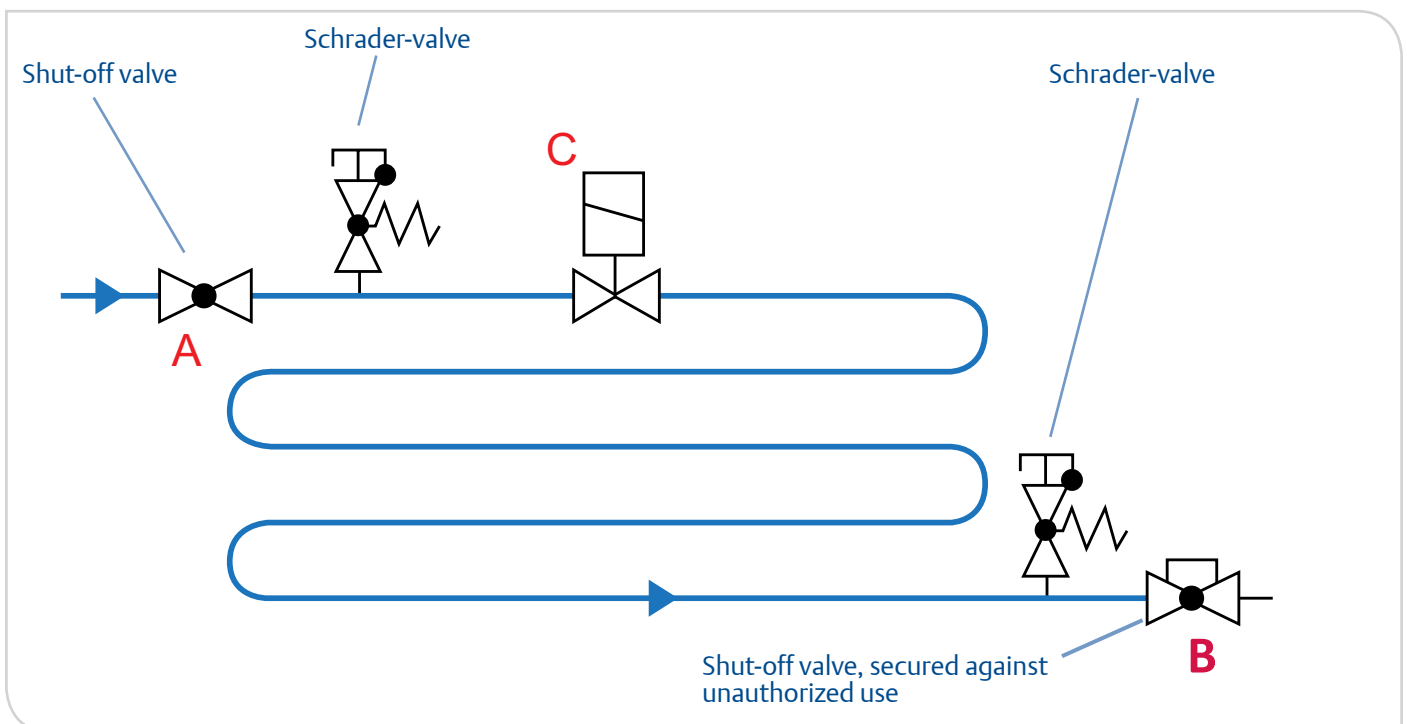

Figure 27. Isolation of components for service

- Monitor the pressure in the coil at the coil outlet through service valve B. This is essential to be sure the refrigerant has been fully removed and that the service valve ahead of the liquid control valve C hasn't become blocked with solid carbon dioxide (R744)

Note: With reference to the above step 3, an estimated time of fifteen minutes would be enough time to ensure a reasonably frost free coil with the fan running. When all frosting on the coil has stopped, the liquid has evaporated.

### Isolation of Filter dryer for service

The procedure below is an example for isolating the filter drier in the liquid line of a cascade system. The example in figure 27 shows a typical arrangement of isolation and bypass valves.

Explanation of the below circuit:

- Valve 1 is closed
- After approximately 15 minutes valve 2 is closed and valve 3 opened
- A suitable gauge manifold set is fitted to the drier core housing
- The remaining R744 is carefully vented via the gauge manifold

It is probable that dry ice will have formed in the drier housing as it is usually not possible to remove all the liquid from the housing, as shown in the example in figure 29. It will deposit to solid when the pressure is reduced during venting. It will have a surface temperature of approximately  $-78^{\circ}\text{C}$  so it should be carefully handled. Because of the low temperature, moisture will condense on the inside of the housing (see figure 30) – it is essential this is removed to avoid the moisture related problems outlined earlier.

Before putting the drier back into service it should be evacuated. Gas should be charged into the drier housing to above the triple-point pressure before opening it up to the liquid line to avoid dry ice formation. The gas can be taken from an R744 gas off-take cylinder or from the suction of the system.

### Charging Compressor Oil

If oil needs to be added into the system it must be the correct type – oils of a different make or viscosity should not be mixed. Copeland R744 compressors use lubricant RL68HB.

Care should be taken when oil is added to avoid moisture and air ingress to the system. The oil should be pumped and not poured into the system. Oil should not be charged into a system if the container has been opened previously.

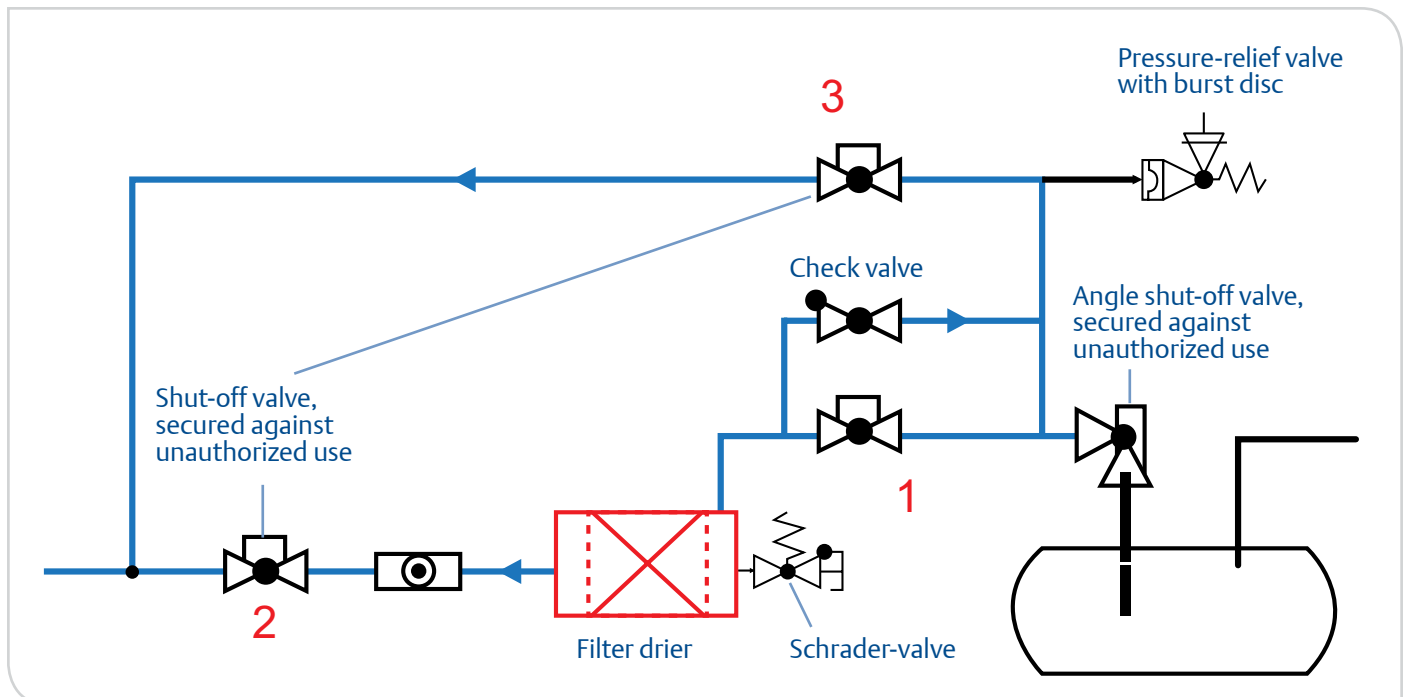

Figure 28. Isolation of filter dryer for service



Figure 29. Example of dry ice formation in a drier



Figure 30. Example of moisture on the flange of a drier

### Section 5. Taking the System Temporarily Out of Service

If a system is to be switched off, it is possible that the standstill pressure will be above the discharge pressure of some or all of the pressure-relief valves. If there is an auxiliary cooling system it is possible that this can be used to keep the pressure below the PRV discharge pressures for short periods of time if there is no load on the system. Otherwise the refrigerant should either be:

- Vented from the system, or
- Pumped down into the high side of the system of the receiver if large enough and if the pressure will not cause the high side PRVs to discharge. For transcritical systems, as well as the receiver-outlet valve or liquid-line solenoid valve, the receiver pressure-regulating valve should be closed to achieve a pump down.

### Section 6. Maintenance

R744 systems should be maintained in accordance with good refrigeration practice. This would include:

- A general check of the system condition
- Check oil level
- Check refrigerant level
- Inspect and test safety cut-outs, transducers and sensors
- Change oil filters and filter driers as required
- Carry out an acid test on a sample of oil
- Check R744 detectors and alarms
- Check control valve operation in line with manufacturers, guidance
- Check plant room ventilation

## Conclusion

High pressure CO<sub>2</sub> systems were already developed end of the 19th century and used in many refrigeration applications. In the last 15 years this technology was identified as an environmental friendly solution in commercial refrigeration based on the low Global Warming Potential (GWP) of CO<sub>2</sub> and resulting in lower Total Equivalent Warming Impact (TEWI) compared with HFC Refrigerants. The applications are mainly cold stores and supermarket retail systems.

Different system concepts for cold and warm climates like indirect secondary systems, cascade or booster systems were developed. Especially in cold climates the CO<sub>2</sub> systems can show better energy efficiency compared with HFC systems, because the temperature profile allow the subcritical operation with very high coefficient of performance. In warm climates cascade systems using CO<sub>2</sub> in the low temperature stage and a low GWP refrigerant for the medium temperature could be a high efficient solution. Furthermore, CO<sub>2</sub> is ideal for heat recovery and combine heating and cooling at the same time which results in a significant reduction of the CO<sub>2</sub> emissions of the building. Tools like the “Right Balance Calculator”

can help to identify the best solution for the environment impact (TEWI), investment and energy cost.

CO<sub>2</sub> provides is a viable option to deal with today’s and future environmental challenges.

Temperatures of both load and ambient may be unchanged, but the physical properties of CO<sub>2</sub> cause it to behave in a different way under the conditions needed to deal with the medium and low temperature refrigeration requirements. In particular, the pressure, and phase change behaviour are very different to fluids previously chosen for vapor compression systems. These properties can offer significant advantages over traditional technologies, but in order to take advantage of this it is necessary to come to terms with those properties.

There is a real advantage in developing a CO<sub>2</sub> competent team giving a competitive edge, driving up industry standards, and leading to more end user respect. This can only benefit the industry as a whole, and Emerson is dedicated to supporting clients working to achieve these objectives.









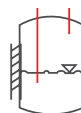

## Glossary

The table below provides definitions of terms relating to CO<sub>2</sub>. Other refrigeration terms are defined in EN378, various other publications and text books.

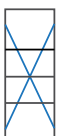
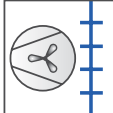
<b>Booster</b>	A two-stage system where the low-stage compressor(s) discharge into the suction of the high-stage compressor(s).
<b>Cascade</b>	A two-stage system where the heat rejected by the low-stage system is absorbed by the evaporating refrigerant in the high-stage system.
<b>Cascade heat exchanger</b>	The evaporator of the high-stage system and the condenser of the low-stage system in a cascade. The evaporating high-stage refrigerant absorbs the heat rejected by the condensing low-stage refrigerant.
<b>Cascade low-stage</b>	The part of the cascade system that provides the cooling. In retail systems this will run often on R744. The pressure will usually be higher than the high-stage (see below).
<b>Cascade high-stage</b>	The part of the cascade system that absorbs the heat from the condensing low-stage refrigerant and rejects it, usually to ambient air.
<b>Critical point</b>	Condition above which distinct liquid and gas phases do not exist.
<b>Deposition</b>	Process of gas transforming to solid.
<b>Dry ice</b>	Solid form of carbon dioxide.
<b>Gas</b>	State when temperature is above the critical temperature but pressure is below critical pressure.
<b>Gas cooler pressure-regulating valve</b>	The valve that regulates the pressure in the gas cooler and associated pipe work. It is controlled from the pressure and temperature at the outlet of the gas cooler. It is also called the high-pressure regulating valve.
<b>Interstage</b>	The section of a booster system between the discharge of the low-stage compressor(s) and the suction of the high-stage compressor(s).
<b>Intermediate</b>	The section of a transcritical system between the outlet of the gas cooler pressure-regulating valve and the inlet of the receiver pressure-regulating valves and the inlet of the expansion devices.
<b>PS</b>	The maximum allowable pressure.
<b>Receiver pressure regulating valve</b>	The valve that regulates the pressure in the liquid receiver and associated pipe work. It is also called the medium pressure regulating valve or the flash-gas bypass valve.
<b>Subcritical system</b>	A system that operates below the critical point.
<b>Sublimation</b>	Transition from solid to gas without passing through the liquid phase.
<b>Transcritical fluid</b>	State when both the temperature and the pressure are above the critical point. The substance is not a gas, vapor or liquid.
<b>Transcritical system</b>	A system which operates above the critical point. Many transcritical systems are subcritical for a proportion of the year.
<b>Triple point</b>	Condition at which solid, liquid and gas coexist.
<b>Vapor</b>	State where temperature and pressure are below critical conditions.
<b>Volatile</b>	A volatile substance is one that evaporates readily at normal temperatures.

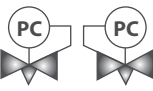

The table below provides information about the symbols that are shown in the circuits in chapters 3 and 4.

	Compressor		Liquid Receiver (flash tank)
	Piston Compressor		Liquid Receiver
	Gas Cooler/ Condenser		Cascade Heat Exchanger/ Heat Recovery Heat Exchanger
	Evaporator		Liquid Pump
	Expansion Device		Oil Separator and Oil Return System
	Gas Cooler Regulating Valve		

## List of Figures

Figure 1, Copeland™ Stream compressor for R744	4
Figure 2, Copeland™ Scroll ZO compressor for R744	4
Figure 3, R744 / CO <sub>2</sub> phase diagram	6
Figure 4. Pressure enthalpy chart for R744	7
Figure 5. Pressure temperature relationship comparison	8
Figure 6. R744 pressure enthalpy chart showing subcritical and transcritical systems	8
Figure 7. Relationship between temperature and pressure of trapped liquid R744. Source: Danish Technological Institute	11
Figure 8. Simple transcritical system for medium temperature	14
Figure 9. Pressure enthalpy chart showing transcritical operation	15
Figure 10. Simple pressure control	16
Figure 11. Simple booster system without oil management	17
Figure 12. Simple cascade system	17
Figure 13, Retail cascade system	18
Figure 14. Simple pump system secondary	19
Figure 15. Comparison of system types, southern Europe	20
Figure 16. Variables used in comparison calculations	21
Figure 17. Pressure enthalpy chart showing two interstage conditions	22
Figure 18. Typical retail transcritical booster system	23
Figure 19. Typical retail cascade system	24
Figure 20. Combined pump circulation system for MT with LT booster system	26
Figure 21. Comparison of HFC and R744 capacities in typical systems	29
Figure 22, Comparison of pipe sizes for typical systems	29
Figure 23. Heat Reclaim comparison of R134a system to R744 transcritical system	31
Figure 24. Example of regulator suitable for pressure testing transcritical R744 systems	33
Figure 25. Example of R744 charging equipment	34
Figure 26. Example of an electronic leak detector suitable for R744	35
Figure 27. Isolation of components for service	36
Figure 28. Isolation of filter dryer for service	37
Figure 29. Example of dry ice formation in a drier	38
Figure 30. Example of moisture on the flange of a drier	38

## List of Tables

Table 1, How R744 meets different conditions and criterias .....	5
Table 2. Basic properties of R744 compared with other refrigerants .....	7
Table 3. Theoretical comparison between R744 and common HFC refrigerants with the performance of ideal cycles .....	9
Table 4. Effects of CO <sub>2</sub> at various concentrations in air .....	10
Table 5. R744 standstill and typical system operating pressures .....	10
Table 6. Comparison of R744 with other refrigerants .....	12
Table 7. Advantages and disadvantages of R744 as a refrigerant .....	13
Table 8. Advantages and disadvantages of cascade and transcritical retail systems .....	19
Table 9. Advantages and disadvantages of two typical intermediate pressures .....	23
Table 10. Reference table .....	23
Table 11, Reference table .....	24
Table 12. Reference table .....	26
Table 13. Typical R744 pressures in retail systems .....	27
Table 14. Maximum pressure of a range of copper tube, calculated using EN14276-2:2007 and EN13480-3:2002 .....	30
Table 15. Steel pipe withstands a greater pressure than copper tube.....	30
Table 16a. Copper pipe sizes and their maximum spacing of supports .....	30
Table 16b. Steel pipe sizes and their maximum spacing of supports .....	30
Table 17. Pipe diameters for copper and steel pipes .....	32
Table 18. Maximum solubility of moisture in R744.....	33
Table 19. F-gas regulation leak check .....	35

## List of References

International Institute of Refrigeration 2011, *CO<sub>2</sub> as a Refrigerant*. Editor: Dr A. B. Pearson. First Edition, Paris, France.

The Right Balance Calculator, *Refrigerant Choices for Commercial Refrigeration*. Emerson Climate Technologies, [www.emersonclimate.eu](http://www.emersonclimate.eu).

p,h-Diagrams by ILK Dresden, Institut für Luft- und Kältetechnik gGmbH, Germany.



## Emerson Climate Technologies at a Glance

Emerson Climate Technologies is the world's leading provider of heating, ventilation, air conditioning, and refrigeration solutions for residential, industrial and commercial applications. We combine technically superior products and services from our industry leading divisions

and brands with our global engineering, design and distribution capabilities to create reliable, energy efficient climate systems that improve human comfort, safeguard food, and protect the environment.

TGE-175-EN-1409

For more details, see [www.emersonclimate.eu](http://www.emersonclimate.eu)

Emerson Climate Technologies - European Headquarters - Pascalstrasse 65 - 52076 Aachen, Germany

Tel. +49 (0) 2408 929 0 - Fax: +49 (0) 2408 929 570 - Internet: [www.emersonclimate.eu](http://www.emersonclimate.eu)

The Emerson Climate Technologies logo is a trademark and service mark of Emerson Electric Co. Emerson Climate Technologies Inc. is a subsidiary of Emerson Electric Co. Copeland is a registered trademark and Copeland Scroll is a trademark of Emerson Climate Technologies Inc.. All other trademarks are property of their respective owners. Emerson Climate Technologies GmbH shall not be liable for errors in the stated capacities, dimensions, etc., as well as typographic errors. Products, specifications, designs and technical data contained in this document are subject to modification by us without prior notice. Illustrations are not binding.

© 2014 Emerson Climate Technologies, Inc.

**EMERSON. CONSIDER IT SOLVED.™**