



CO₂ in Europe's supermarkets -
Carrier's day-to-day business

Lothar Serwas, Manager CO2OLtec Sales

CURRENT STATE AND HISTORICAL TREND

Carrier[®] CO₂ HFC/CO₂ subcritical projects in Europe

TOTAL
409

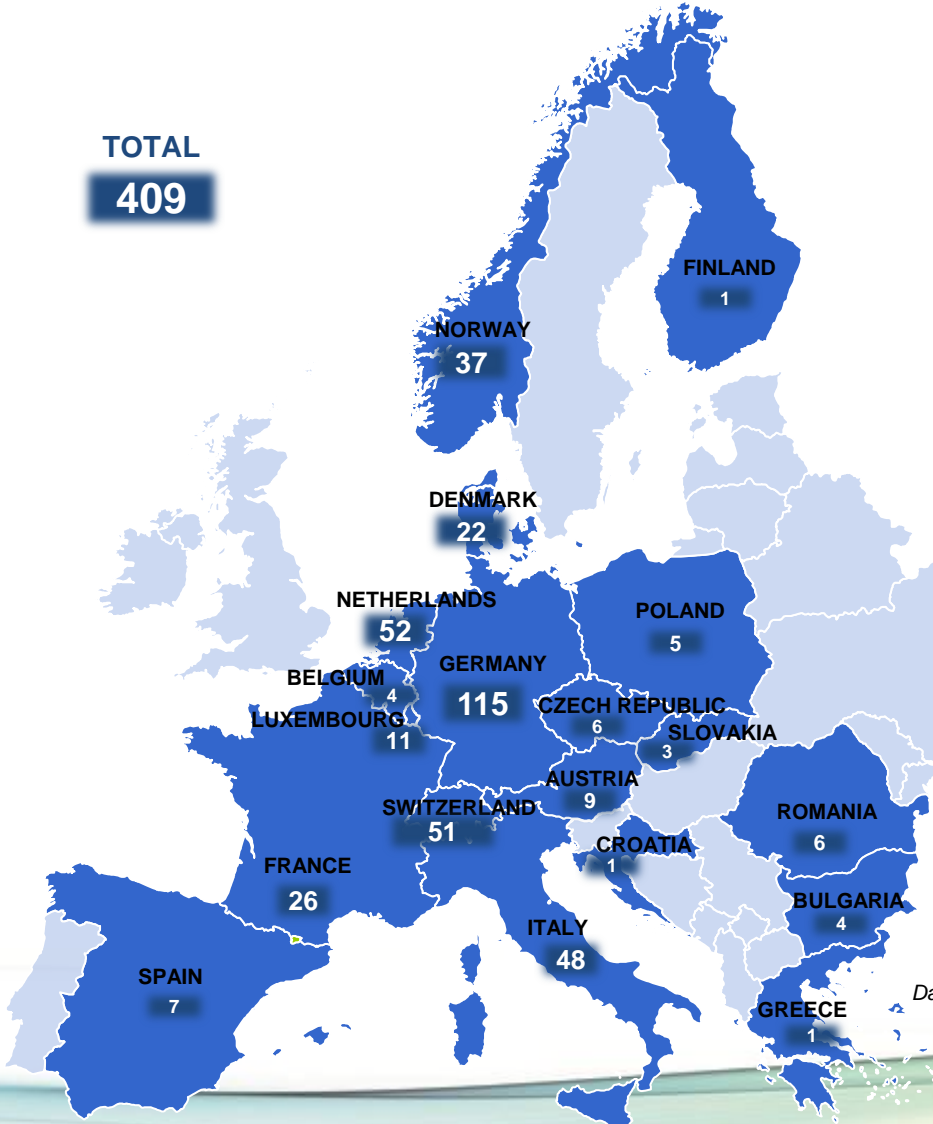

Market uptake trend
Turnkey stores in operation

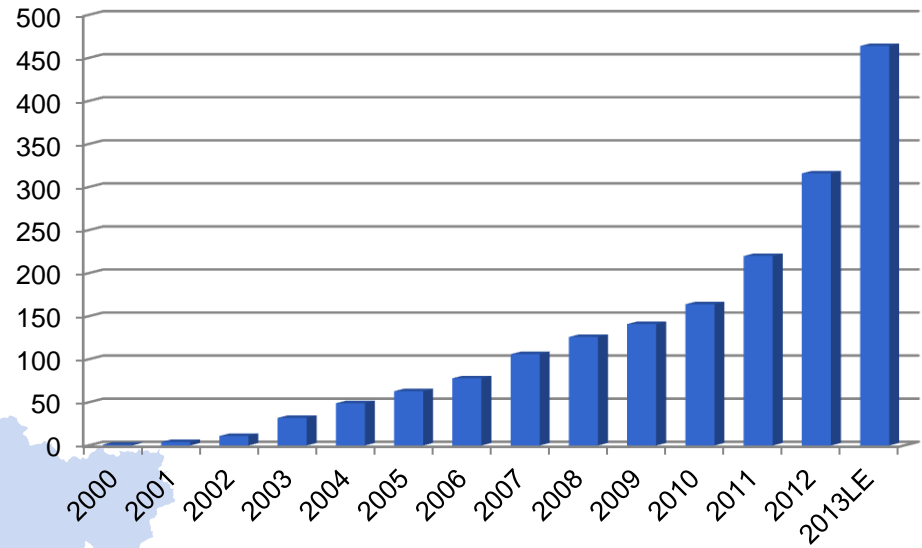

HybridCOOL₂

Source: Carrier
Data by country end of September 2013



CURRENT STATE AND HISTORICAL TREND

Carrier[®] CO₂ transcritical projects in Europe

TOTAL
677

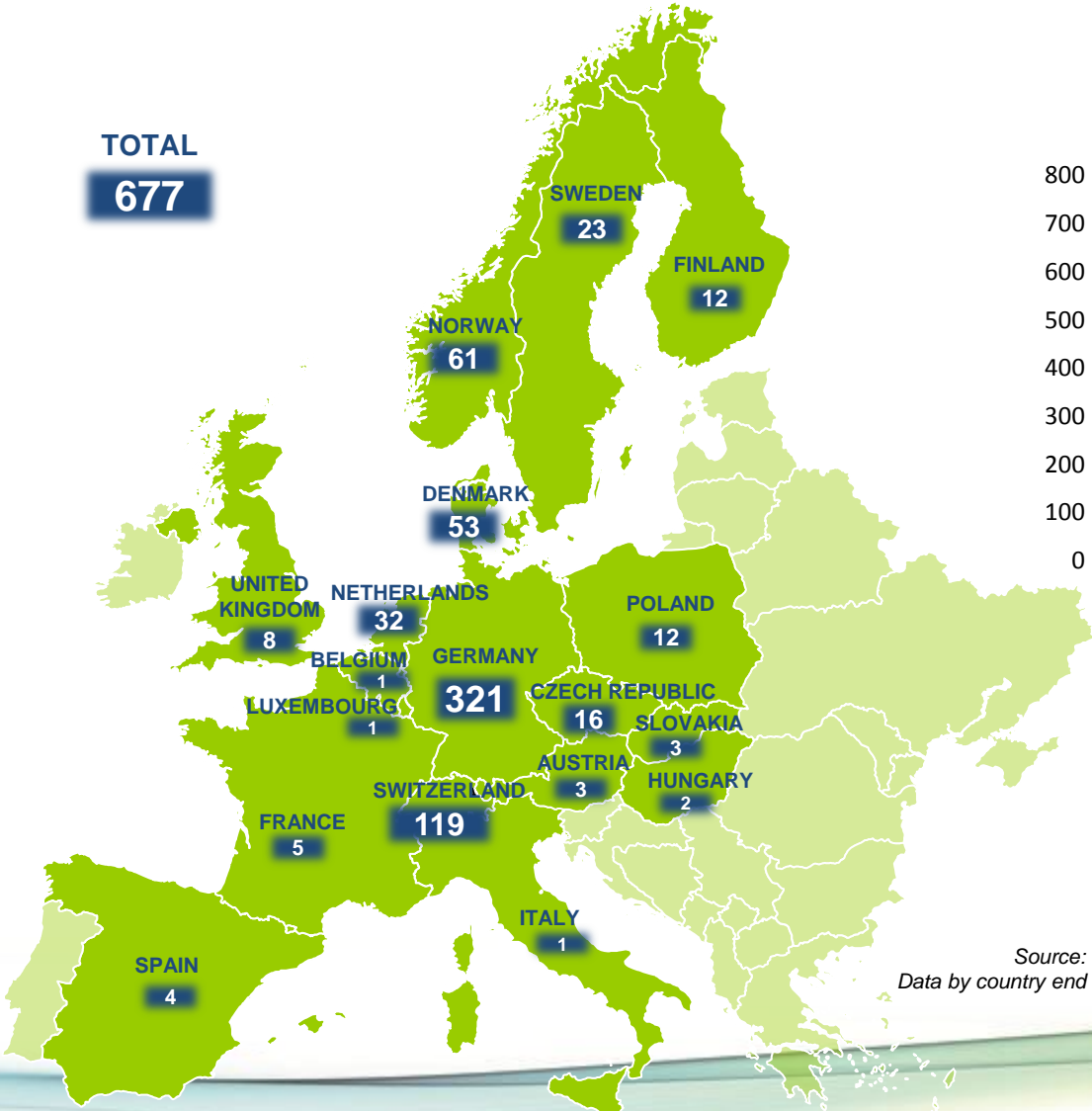

Market uptake trend
Turnkey stores in operation

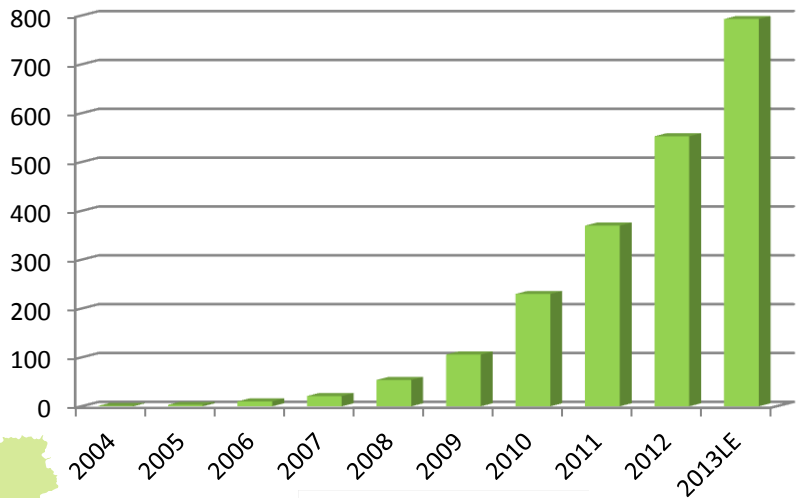

Source: Carrier
Data by country end of September 2013



NATURAL REFRIGERANTS

Building on success: factors for market growth

combining technical skills & organizational capabilities...

- state of the art innovation process
- design, turn key, start-up & service
- system reliability & efficiency
- energy efficient coverage across Europe

...and gaining trust to overcome scepticism

- consistent communication & promotion
- transfer of technology know-how
- guiding legislation and supportive incentives

comprehensive
market success



ENERGY EFFICIENCY STUDY GERMANY

126 discount stores, super- and hypermarkets

“making success visible...”

Comparison of the refrigeration installations using VDMA Efficiency Quickcheck (www.vdma-effizienz-quickcheck.org) based on measured field data

93 stores with insulated glass door share* below 20%

10 stores with insulated glass door share* between 20% and 80%

23 stores with insulated glass door share* above 80 %

42 stores with R404A systems

11 stores with R134a/CO₂ cascade systems

40 stores with CO₂ booster systems



ENERGY EFFICIENCY STUDY GERMANY

VDMA Data over time and system

(93 stores, glass door share below 20%)

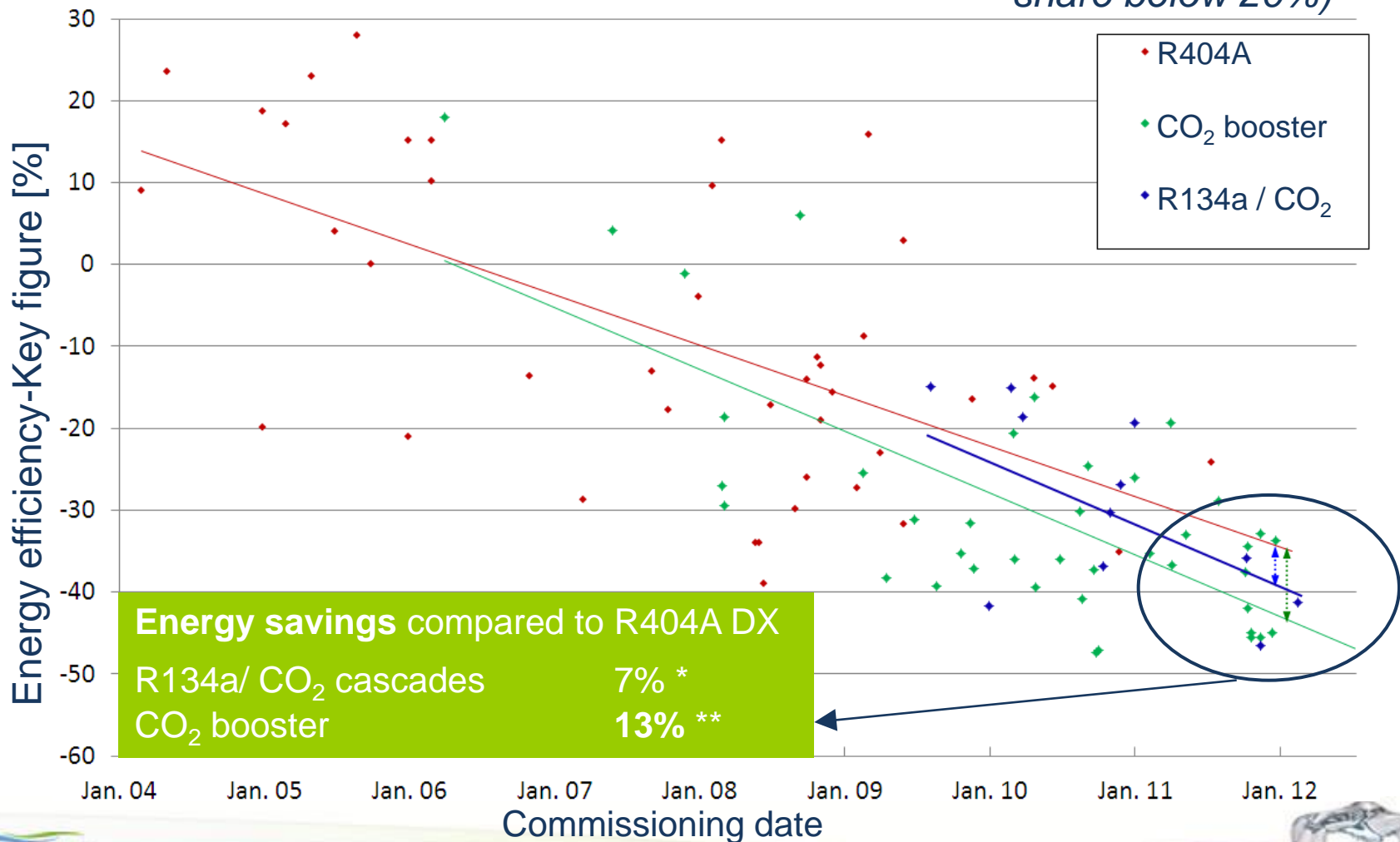

CO₂ HIGH EFFICIENCY

CO₂ transcritical - solutions for warm climates



Efficiency

Proven energy efficiency of transcritical CO₂ DX systems in cold to mild climates

Innovation

Next generation CO₂ DX systems being developed and field tested

Targeting attractive energy performance across all of Europe, eliminating current *“CO₂ equator”*



INNOVATION

CO₂ transcritical - solutions for warm climates

Update status:

Economizer installations
in Germany, Switzerland,
Italy and Spain

Mechanical subcooler
installations in Spain

Ejector, lab testing
in Carrier R&D centre

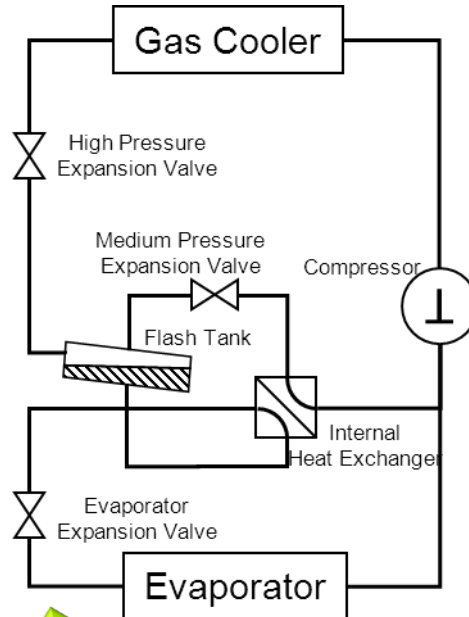

Mechanical Subcooler

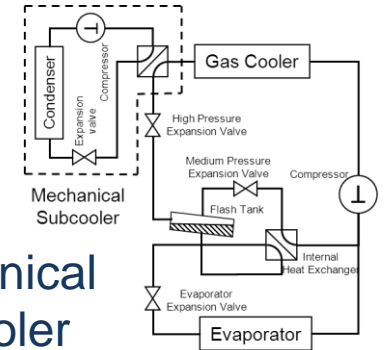

Ejector

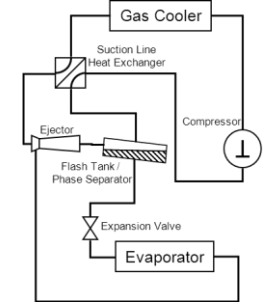

Expander

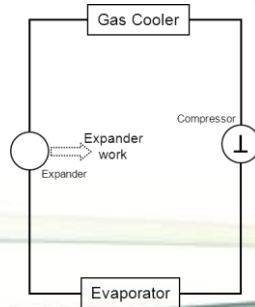

Economizer

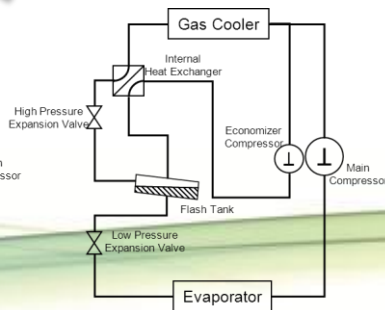
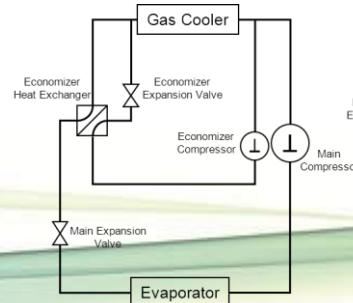

CO₂ BOOSTER + HC SUBCOOLER

Development target metrics

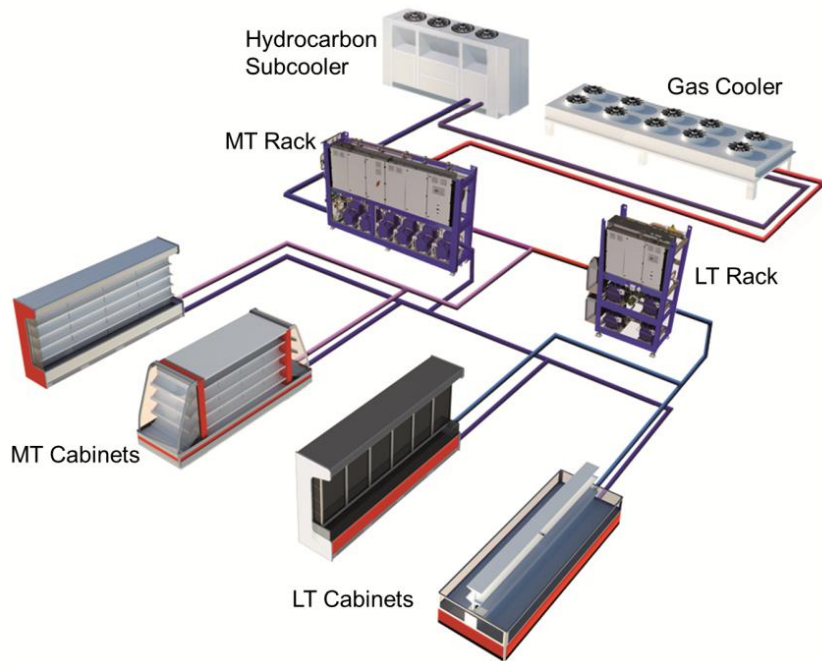

- Energy consumption equal to HFC systems in southern European climate
- CO₂ MT rack capacity gains of more than 30% in southern European climate
- Installed cost €/kW MT equal to existing CO₂ range
- Operational reliability equal to standard CO₂ transcritical
- Serviceability equal to established technologies

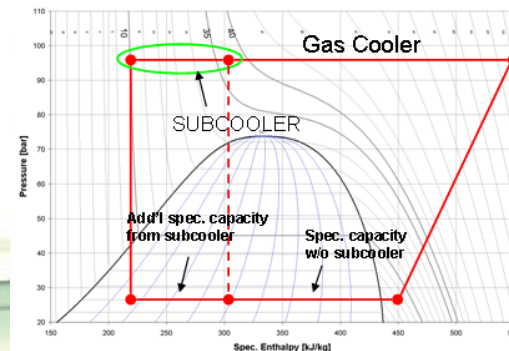

CO₂ BOOSTER + HC SUBCOOLER

Data from Spanish field trial



*Hydrocarbon subcooler,
add-on to CO₂ transcritical
DX system*

- Application: Food retail supermarket
- Location: Northwest Spain
(2 further projects in Madrid and Southeast Spain under installation)
- CO₂ transcritical booster concept with add-on, roof-top mounted HC subcooler for warm climate
- MT refrigeration capacity: 310 kW
- Commissioning: October 2012



CO₂ BOOSTER + HC SUBCOOLER

Initial field data

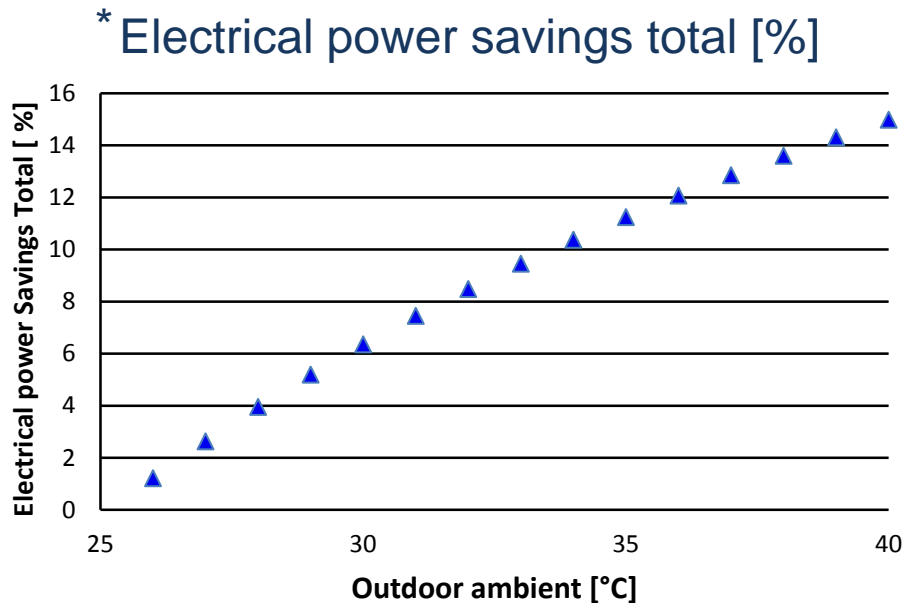

- Two month field data over summer period
- Long-term measurements and analysis needed
- Optimisation potentials
- Data proving efficiency increase in warm climate
- Reliable, efficient operation

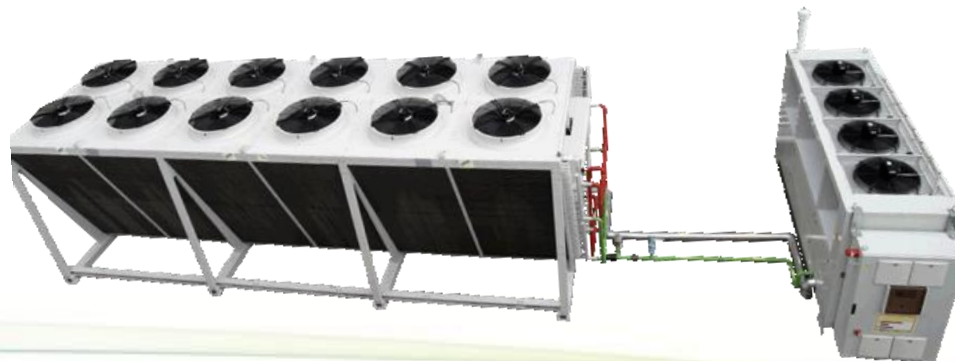

COOLtec

* turnkey scope: refrigeration systems, gas cooler, other equipment (cabinets, cold room air coolers, ice machines...)



SUMMARY

CO₂ acknowledged to become market standard

CO₂ sub- / transcritical turnkey represents 30%+ share of total Carrier turnkey in 2013 - with rapidly growing importance

Turnkey CO₂ installations provide a 10%+ energy efficiency advantage in Germany

Huge potential to eliminate current “CO₂ equator” across Europe by utilising existing technologies.

CO₂ in Europe's supermarkets -
Carrier's day-to-day business

 COOLtec





© United Technologies

Thank you for your attention!
For further information please visit our website
www.carrier.com

Innovative solutions,
naturally...



Carrier has the right refrigerant for every application, but every application will not have the same refrigerant solution.